

Illuminated Laser Sign Build Instructions

Purpose:

This build instruction is for illuminated laser signs to be posted at the entrances of Class 4 laser labs and use areas to meet the requirements of ANSI Z136.1 subpart 4.4.2.8.

Scope:

This build instruction will cover three (3) variations of an illuminated laser sign including a 120V hardwire connection for permanent installation, a 12V semi-permanent build for installation by non-electrical professionals, and a 12V battery operated portable version for temporary work locations and installations.

Build Instructions: 120V Hardwire Connection

NOTE: This build requires connection to a voltage source above 50V, and can only be completed by a trained and certified electrician. Do **NOT** attempt this build without active LOTO authorization.

Example:



Example: 'ON'

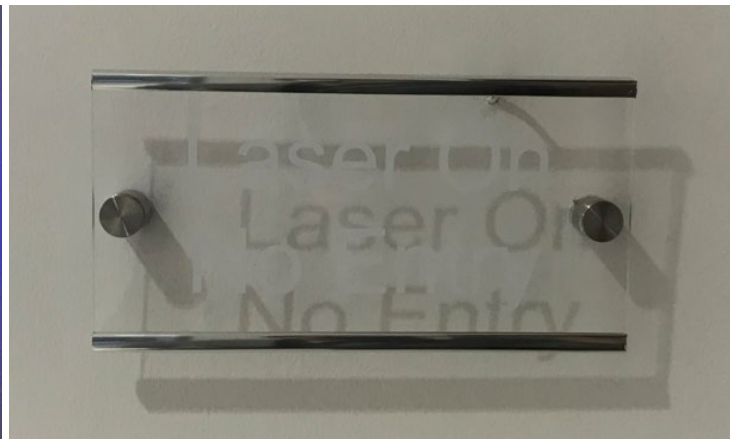

Example: 'OFF'

Tools: The following tools will be needed for the build.

- | | | | |
|-------------------------------|--------------------------------------|-----------|-----------------------|
| Wire Cutters / Strippers | Drill – Phillips / Flat / Drill Bits | LOTO Lock | Sheetrock Saw / Knife |
| Screwdriver – Phillips & Flat | Stud Screws | Paint | Sheetrock Patch |
| Ladder | Studfinder | Wire Nuts | 14-18 Gauge Wire |

Parts: The following parts will be needed for the build and can be found at the provided link.

#	Part Name	Vendor	Description	Quantity	Price (\$)
1	Acrylic Sign	Fire Light Laser	8 x 4 inch "Laser On No Entry" edge lit cast acrylic 1/8" thick	1	8.00

**The University of Texas at Austin
Laser Safety Program**

EHS-LAS-B-001

Rev. 01;
09/19/2023

Illuminated Laser Sign Build Instructions

2	LED Light Strip	LumenEdge	Polished Chrome Unpowered LED Light Strip For 1/8" Panel - 8", Select Color, No Switch, Out the Back, 6ft of wire with 2.1x5.5mm Barrel Connector	1	12.27
3	Chrome LED Reflector	LumenEdge	Polished Chrome Reflector Strip For 1/8" Panel - 8"	1	1.98
4	Acrylic Sign Standoff Wall Mount	Amazon	3/4 x 1.2 Inch Sign Holders Standoff (2x needed for each sign)	2	1.00
5	Power Converter	Mean Well	RS-15-12 Power Supply, AC-DC, 12V, 1.3A, 100-264V In, Enclosed, Pnl Mnt, Embedded, 16W, RS Series	1	10.70
6	12V Blinker Module	Amazon	2 Packs 2-Pin 12V Electronic LED Flasher Relay LF1-S-PIN MAX 150W - Rate Control Flasher Relay for Motorcycle Fixes Turn Signal Bulbs Hyper Flash	1	6.50
7	Junction Box #1	Amazon	BUD Industries JB-3950-KO Steel NEMA 1 Sheet Metal Junction Box 4 L x 4 W x 3 H, Gray	1	13.88
8	Junction Box #2	Amazon	Hardware 1-Gang PVC Old Work Electrical Outlet Box (1-Pack) 14 cu. in. Plastic Junction Box for Switches, GFCI, or Duplex Receptacle Outlet Electrical Box for Home Improvement	1	1.99
9	120V/20A 4-Way On/Off Light Switch	Amazon	ENERLITES 4-Way Toggle Light Switch, Four Way, Side Wiring, Copper Wire Only, Grounding Screw, Residential Grade, 15A 125VAC 60Hz, UL Listed, 84150-W, White	1	9.99
10	Light Switch Cover	Various	Oversized Wall Plate Cover, 1 Gang, Light switch cover, 3.1" x 4.9", Outlet Covers, Screws Included, White, 30598	1	2.00
				Total:	\$68.31

Instructions:

1. At the entrance to the lab, determine the mounting location of the sign. Ideally chest to head height, directly beside the entranceway.
2. Using the studfinder, determine the location of the nearest stud for mounting of the junction boxes.
3. Follow your LOTO procedures for identifying the isolating the nearest circuit you will tie into.
4. Cut a hole(s) in the wall to allow mounting of the junction boxes to a stud.
5. Mount the junction boxes to the desired stud. Junction box #1 is often mounted on the same stud directly above Junction box #2.
6. With the junction boxes mounted, assemble the LED sign by removing the protective tape, and attaching the chrome reflector and LED light bar.
7. Cut the LED barrel jack from the wire leaving as much length needed to reach the inside of the junction box #1 from the mounted location.

Illuminated Laser Sign Build Instructions



Example: LED Light Assembly

8. Using the drill, make two pilot holes for the provided sheetrock screws (included with sign mounts), then place the plastic screw guides within the hole.
9. Determine location for LED wire to feed through the wall, then drill a hole for a wire grommet to be inserted.
10. With the sign mounts unscrewed, attach the long portion of the mount to the sheetrock screw guides.
11. Attach the sign to the wall by connecting the sign standoff portions together with the acrylic sign in between.
12. Feed the LED cable through the grommeted hole and pull to the mounted junction box #1.

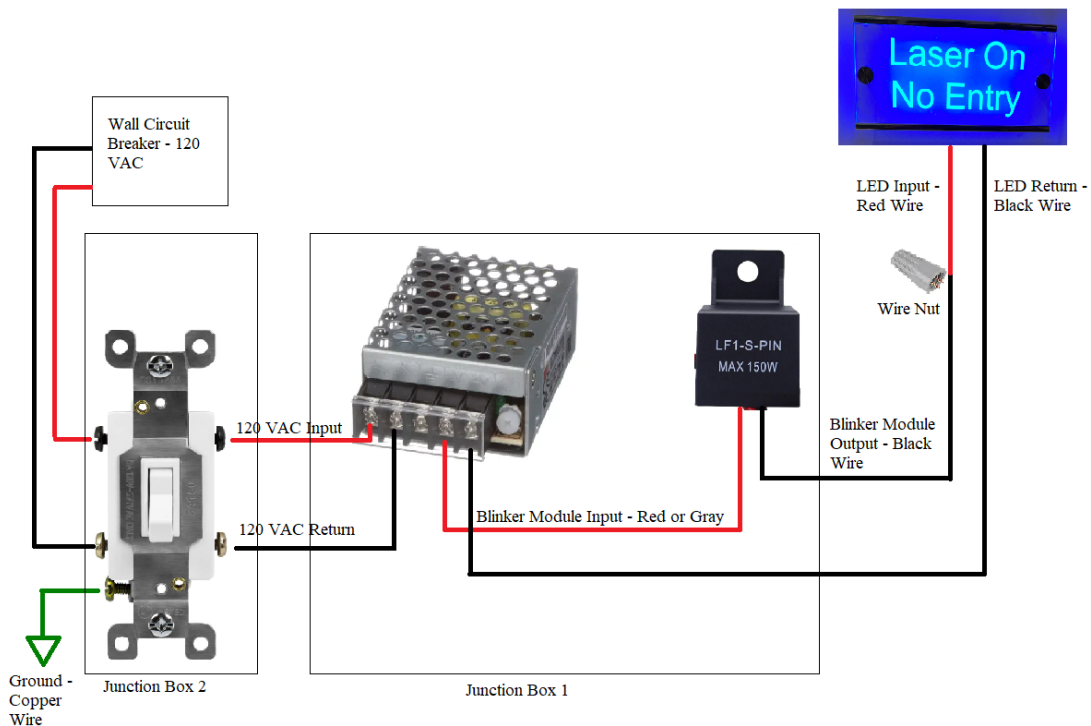

Illuminated Laser Sign Build Instructions

Figure 1: 120 VAC Illuminated Laser Sign Wiring Diagram

13. With the circuit being tied into Locked Out and Tagged Out, assemble the LED circuit per the diagram shown above. Use the junction box knockouts to feed all wires through. Use wire nuts for all wire to wire connections, do **NOT** use tape.
NOTE: If the blinker module is assembled in reverse, the LED will not blink but rather remain a constant ON.
14. Connect the light switch to the 120VAC -12VDC transformer as shown in figure 1 using the 14-18 gauge wire.
15. Connect the light switch to the 120VAC lines as well as ground.
NOTE: Failure to connect the light switch to ground can lead to electrical and fire hazards. Follow all codes and procedures when tying into 120VAC lines.
16. Mount the light switch to the front of the junction box, and place the light switch cover using the provided screws.
17. Remove the Lockout following the LOTO procedures, and test the light for proper operation.
18. Once proper operation is confirmed, ensure junction box 1 is properly sealed with front cover.
19. Remove the light switch cover prior to placing drywall patch and painting.
20. Place drywall patch over the cutout that was created, and spackle to fill gaps between patch and wall.
Let the spackling dry.
21. Paint the cutout area and let dry.
22. Mount the light switch cover.

Illuminated Laser Sign Build Instructions

Build Instructions: 12V Semi-Permanent Installation

Example:



Tools: The following tools will be needed for the build.

- | | | | |
|-----------------------------------|--------------------------------|------------------------|------------------|
| Wire Cutters / Stripper / Crimper | Drill – Phillips / Stepper Bit | Heat Gun / Heat Shrink | Box Cutter |
| Screwdriver – Phillips & Flat | Ladder | Wire Nuts & Crimps | 18-22 Gauge Wire |

Parts: The following parts will be needed for the build and can be found at the provided link.

#	Part Name	Vendor	Description	Quantity	Price (\$)
1	Acrylic Sign	Fire Light Laser	8 x 4 inch "Laser On No Entry" edge lit cast acrylic 1/8" thick	1	8.00
2	LED Light Strip	LumenEdge	Polished Chrome Unpowered LED Light Strip For 1/8" Panel - 8", Select Color, No Switch, Out the Back, 6ft of wire with 2.1x5.5mm Barrel Connector	1	12.27
3	Chrome LED Reflector	LumenEdge	Polished Chrome Reflector Strip For 1/8" Panel - 8"	1	1.98
4	Acrylic Sign Standoff Wall Mount	Amazon	3/4 x 1.2 Inch Sign Holders Standoff (2x needed for each sign)	2	1.00
5	Junction Box	Amazon	Outdoor Junction Box, Nineleaf IP66 Weatherproof Electrical Project Boxes PVC/ABS Plastic Enclosure Box Universal Watertight 4.9 x 3.3 x 2.3 inch (125x86x62mm), Fit with 20mm Cable Gland Grey	1	12.91
6	12V Blinker Module	Amazon	2 Packs 2-Pin 12V Electronic LED Flasher Relay LF1-S-PIN MAX 150W - Rate Control Flasher Relay for Motorcycle Fixes Turn Signal Bulbs Hyper Flash	1	6.50
7	Cable Gland	Amazon	20mm Black Plastic Waterproof Cable Gland M20x1.5	2	1.26

Illuminated Laser Sign Build Instructions

8	Wall Wart 120VAC – 12VDC	Amazon	12V 2A Power Supply AC Adapter, AC 100-240V to DC 12 Volt Transformers, 2.1mm X 5.5mm Wall Plug (12 Volt - 2amp - 2pack)	1	6.50
9	12V On/Off Toggle Switch	Amazon	Waterproof Toggle Switch 12V DC 30A Heavy Duty 2 Pin ON Off SPST with Weatherproof Boot Cap Cover for Auto Car Marine Boat -2 Pack	1	4.00
10	Construction Adhesive	Amazon	Gorilla Heavy Duty Construction Adhesive, 7 Ounce Squeeze Tube, White	1	9.47
				Total:	\$63.89

Instructions:

Sign Assembly

1. Collect Sign Parts and Tools – 1 acrylic sign, 2 wall mount standoffs, 1 LED strip, 1 Chrome Reflector Strip, Wire Cutters/Strippers, Construction Adhesive.
2. Peel off protective plastic layer from acrylic sign, LED strip, and chrome reflector strip
3. Unscrew both wall mount standoffs and place within acrylic sign mounting holes with 1 rubber washer on each side of the acrylic sign. Screw tight by hand.
4. Mount the LED strip on the top side of the sign by enclosing edge of the acrylic with LED strip. Repeat for the chrome reflector on the bottom of the sign.
5. Cut the barrel connector off the end of the 6ft lead wire from the LED strip. Only cut off the barrel connector. The wire length is needed to make it to the ceiling to avoid having wire connections below the ceiling line.
6. Strip the last 1.5” of the outer protective layer (12-14ga) of the LED wire, exposing the 2 inner 22ga wires (red/black). Strip the last .5-.75 of the inner 22ga wires exposing the copper center.



Example: Assembled Light

Junction Box Assembly

1. Collect Junction Box Parts and Tools – 1 Junction Box, 2x 20mm Cable Glands, 1 toggle switch, 1 blinker module, box cutter, drill, stepper bit, Phillips bit, 120V AC – 12V DC Wall Plug

Illuminated Laser Sign Build Instructions

2. Using box cutter, cut out the top and bottom (assuming vertical wall mount) junction box circles by pressing box cutter tip into the junction box pre-mold form. Remove box cutter and repeat until entire circle is cut.

NOTE: Use impact and cut resistant gloves. It's very easy to slip or lose grip and potentially put the box cutter into your hand.

3. Once the top and bottom circles are cut, use drill to open junction box by removing the 4 corner screws. Empty junction box contents (cutouts, manual, plugs)
4. Unscrew a cable gland and place the inner washer inside the junction box aligning with cutout.
5. Screw in the cable gland through the cutout and into the inner plastic washer.
6. Repeat for the other cutout (top or bottom).



Example: Junction Box Cable Gland Assembly

7. Using a regular drill bit (~1/4"), drill pilot hole in the dead center of the junction box lid.
8. Using the stepper bit, expand the hole to 1/2 inch in diameter for the toggle switch to fit through.
9. Remove the outer toggle switch washer and fit the toggle switch through the hole in the junction box lid.
10. Tighten toggle switch washer onto toggle switch. Align the toggle switch to have it 'ON' label on top of the desired junction box orientation.



Illuminated Laser Sign Build Instructions

Example: Toggle Switch Installation

11. On the 12V blinker module, cut off end connection and remove insulating sheath exposing the two inner wires. Strip the 2x (12ga) wires back roughly .5-.75"
12. Loosen the inner wire screws on the 12V toggle switch.
13. Wrap the red/gray (positive) blinker module wire around the 'ON' screw post of the toggle switch and tighten.
NOTE: If installed backwards, the blinker will not work and the light will remain solid while on. The blinker should be in series between the positive terminal of the toggle switch and the input power lead of the LED strip.

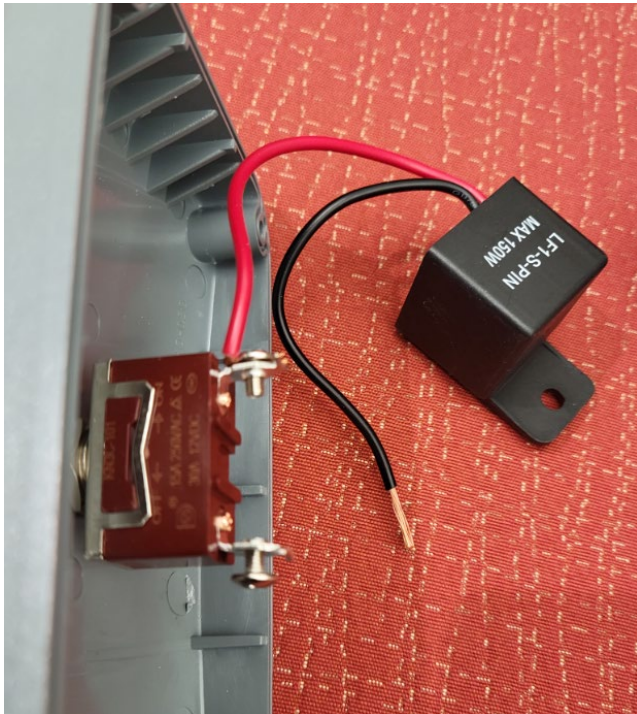

Example: Blinker Module Installation

14. On the 120V AC to 12V DC wall wart plugin, cutoff the connecting end and strip the outer sheath (12ga) back roughly 1.5 inches exposing the two 22ga inner wires (red/black).
15. Cut and place two long strips of the double-sided mounting tape on the backside of the junction box leaving the protective layer in place until mounting.

Illuminated Laser Sign Build Instructions

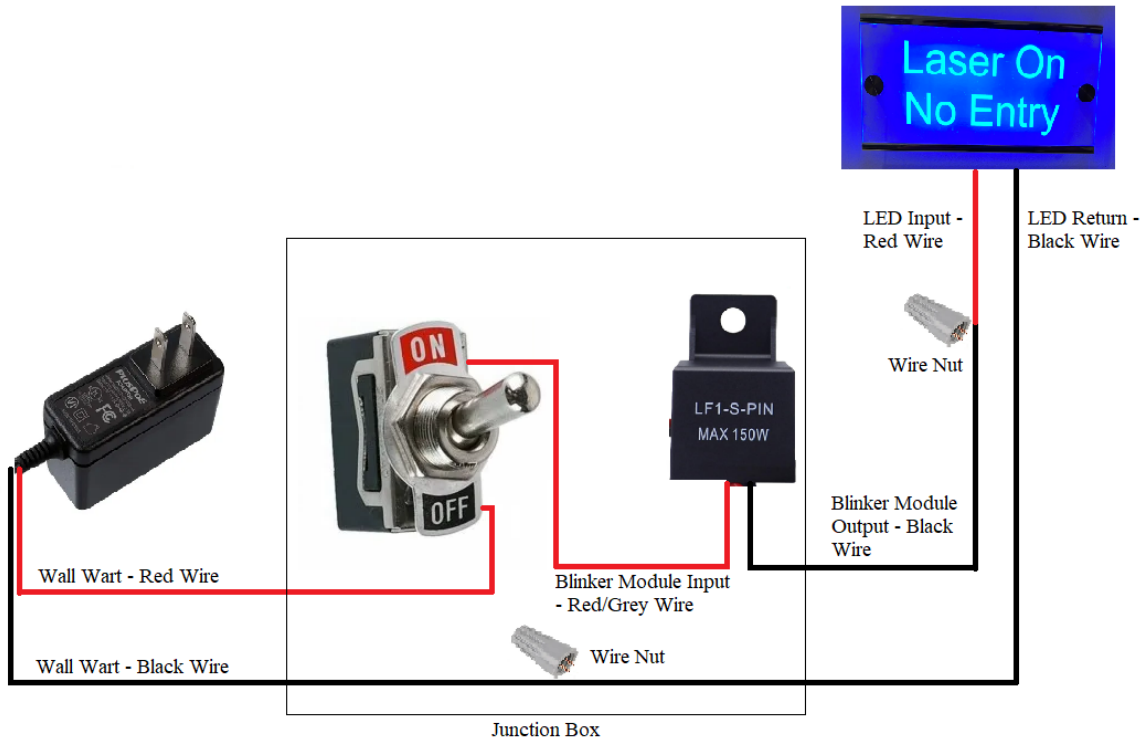

Figure 2: Wall Wart Plugin Wiring Diagram

Mounting Instructions

1. Squeeze dime size drop of the Construction Adhesive to each of the sign mounts and press into final mounting position and hold for 30 seconds. Use painters or masking tape to secure sign in place while adhesive sets. If facilities permits, the provided mounting screws and sheetrock anchors allow for a more secure method of mounting.
2. Repeat for the junction box, using 4x dime size drops in each corner, and mount in the desired location of the light switch.
3. Run the LED wire vertically along the entrance door frame and secure in place using the construction adhesive or 1-2" strips of double-sided tape (1/2 inch width) every 1-2 feet. The wire can be straightened by pinching with index finger and thumb and pulling apart while letting the wire slide in between fingers. This allows for cleaner/straighter look.
4. Run the LED wire vertically through the ceiling tile/panel. The exposed wire ends will hopefully be above the ceiling line (depending on height).
5. Using 16ga AWG wire, cutoff the length needed to span distance from LED wire ends, through the wall, and down to the junction box inside the lab. Often you can run this wire through a hole that is already there and no drilling is needed.
6. Strip the outer 16ga AWG sheath exposing the two 12ga inner wires (red/black).
7. Run the 16ga AWG wire in the desired path.
8. NOTE: Running the wire between the door and frame is possible but not recommended. Repeated use of the door leads to damaged wires fairly easily.
9. Above the ceiling line, connect the LED wire ends to the 16ga AWG wire using wire nuts. Connect red to red, and black to black.

Illuminated Laser Sign Build Instructions

10. Mount the 16ga AWG wire to the wall using the double-sided adhesive tape as done with the LED wire on the outside wall. Run the wire vertically in the crease of the inside door frame.
11. Run the end of the 16ga wire through the top cable gland of the junction box.
12. Connect the red (positive) wire of the 16ga AWG wire to the black (outgoing) wire of the 12V blinker module previously attached to the lid of the junction box. The red/gray (positive) wire of the 12V blinker module should already be attached to the 'ON' terminal of the toggle switch.
NOTE: At this point, the black (negative) wire of the 16ga AWG wire should still be exposed inside the junction box. The lid will have to hang for a while until the wall wart can be installed.
13. Locate a wall outlet where the 12V power converter (wall wart) can be plugged in.
NOTE: Don't plug it in yet until wires are connected and secured.
14. Determine length of extra 16ga AWG wire needed to connect to the junction box.
15. Cut desired length of the 16ga wire and strip ends as before.
16. Run the 16ga through the bottom cable gland of the junction box.
17. Connect the red lead of the 16ga wire to the bottom/OFF terminal of the toggle switch, by loosening the terminal screw, wrapping the exposed lead around the post, and tightening the screw. Be sure you do not ground the wire by having a strand touch other parts.
18. Connect the black (negative) lead of the 16ga wire to the black (return) lead of the LED strip using a wire nut. This will be the black 16ga wire coming from the top cable gland.
NOTE: There should be no exposed wire leads inside the junction box at this point. Do not close up the junction box just yet to allow for potential trouble shooting such as bad connections.
19. The 16ga wire running from the bottom cable gland must now be crimped together and heat shrunk to the leads of the wall wart plugin. Red connects to red, black connects to black.
20. Be sure to place heat shrink on both the inner wires of the 16ga leads, as well as the whole 16ga wire. The leads will need to stay separated/insulated from one another. Crimp and heat shrink each lead to the wall wart lead, and then heat shrink both joints together by sliding the shrink wrap over them and heat shrinking again.
21. Once cooled, you should be able to plug the wall wart in the outlet and have a working sign.
22. Trouble shoot any bad connections or wrongly oriented parts (blinker won't work if backwards).
23. Seal junction box with provided screws and tighten cable glands.

Illuminated Laser Sign Build Instructions

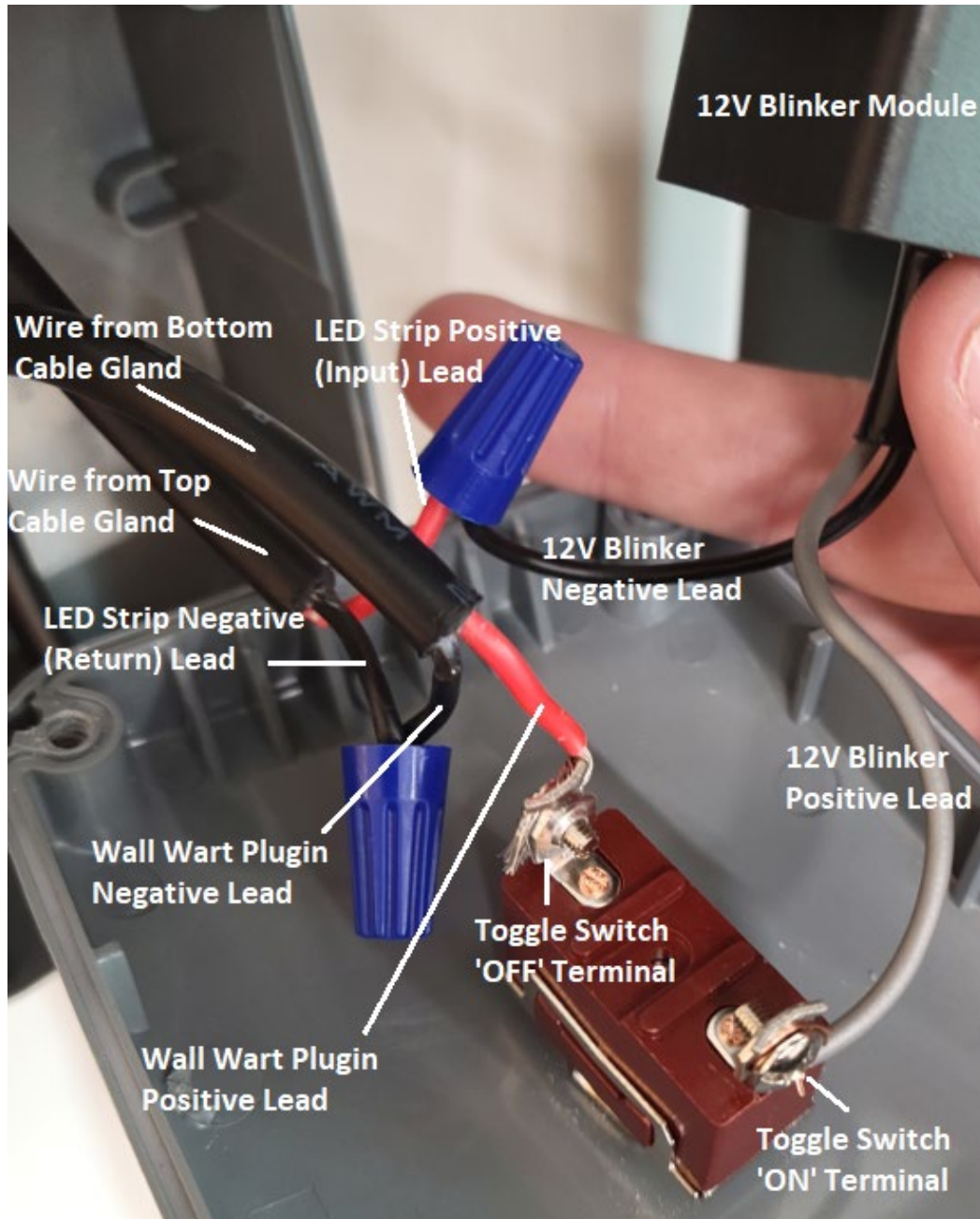

Example: Junction Box Wiring

Illuminated Laser Sign Build Instructions

Build Instructions: 12V Portable Battery Powered Sign

NOTE: This build runs off a portable battery bank and is designed with temporary installations in mind. Using a 13000 mAh battery as shown below, the sign will run for >72 hours continuously. The sign is rechargeable without having to open the case and can be charged using a regular micro USB cable. The battery comes with a reset button to preserve battery power when not in use. This does not effect the operation while the sign is on.

Example:



Tools: The following tools will be needed for the build.

Wire Cutters / Stripper / Crimper Drill – Phillips / Stepper Bit Dremel – Cutter / Sanding Bits Wire Nuts
Hot Glue Gun Double Sided Velcro Scissors

Parts: The following parts will be needed for the build and can be found at the provided link.

#	Part Name	Vendor	Description	Quantity	Price (\$)
1	Acrylic Sign	Fire Light Laser	8 x 4 inch "Laser On No Entry" edge lit cast acrylic 1/8" thick	1	8.00
2	LED Light Strip	LumenEdge	Polished Chrome Unpowered LED Light Strip For 1/8" Panel - 8", Select Color, No Switch, Out the Back, 6ft of wire with 2.1x5.5mm Barrel Connector	1	12.27

**The University of Texas at Austin
Laser Safety Program**

Illuminated Laser Sign Build Instructions

3	Chrome LED Reflector	LumenEdge	Polished Chrome Reflector Strip For 1/8" Panel - 8"	1	1.98
4	Project Box	Amazon	YXQ 263x182x60mm Junction Box Clear Cover IP65 Waterproof ABS Project Case Enclosure Cable (10.4 x 7.2 x 2.4 inches)	1	15.99
5	12V Toggle Switch	Amazon	DaierTek ON Off Round Rocker Switches SPST 20mm Mini 12 Volt DC Mini Circle Toggle Switch 12V for Car Automotive RV 2 Pin Switch 120V Wired KCD1-5Pack	1	1.40
6	12V Blinker Module	Amazon	2 Packs 2-Pin 12V Electronic LED Flasher Relay LF1-S-PIN MAX 150W - Rate Control Flasher Relay for Motorcycle Fixes Turn Signal Bulbs Hyper Flash	1	6.50
7	Battery	Amazon	Anker PowerCore 13000 Portable Charger - Compact 13000mAh 2-Port Ultra Portable Phone Charger Power Bank with PowerIQ and VoltageBoost Technology for iPhone, iPad, Samsung Galaxy (Black)	1	39.99
8	Micro USB Extension	Amazon	YCS Basics Black 6 Inch Cellphone/Tablet USB Micro Male to Female Sync & Charging Extension Cable	1	5.97
9	5V to 12V USB Step Up	Amazon	iGreely DC 5V to DC 12V USB Voltage Step Up Converter Cable Power Supply USB Cable with DC Jack 5.5 x 2.5mm or 5.5 x 2.1mm, USB 5V to DC 12V Cable 3ft	1	7.99
10	White Cardboard	Amazon	uxcell 10pcs Corrugated Cardboard Paper Sheets, White, 7.87-inch x 11.86-inch, for Craft and DIY Projects	1	.99
				Total:	101.10

Instructions:

Project Box Preparation:

1. Determine the desired location of the power switch and charging port. The battery will ideally be mounted at the bottom of the box to ensure it is secure while in the vertical position. The charging port will need to be within the length of the micro USB extension cable to the battery charging port.

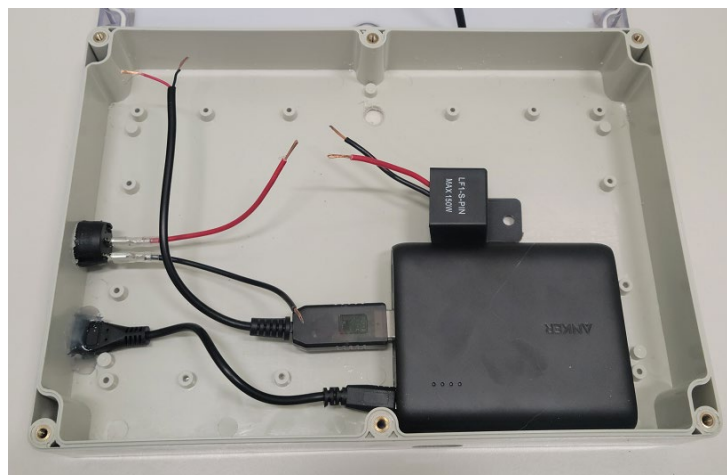

Example: Battery Powered Laser Sign Internal Layout

Illuminated Laser Sign Build Instructions

2. Drill a hole center of where the power switch has been designated. Use the drill stepper bit to expand the whole to accommodate the toggle switch.
3. Drill a hole center of where the external charging port is to be mounted. This is ideally toward the back of the sign to allow for the cable head to be secured against a solid surface.



Example: Power Switch and Charging Port Mounts



Example: Battery Reset Button Port

Illuminated Laser Sign Build Instructions

4. Select the mounting position of the battery, ensuring the reset button is against the surface of the project box sides.
5. Drill a hole where the reset button meets the project box. Use the Dremel tool to expand the hole and sand to smooth the hole edges.
6. Place the toggle switch through the mounting hole and connect the provided leads per Figure 3 below.
7. Using the hot glue gun, secure the micro USB extension cable head through the external charging port.
8. Using hot glue or double-sided Velcro, mount the battery pack with the reset button accessible from the hole dremeled in step 5.

LED Lid Preparation:

1. Collect sign parts including acrylic sign, LED light bar, chrome reflector strip.
2. Assemble acrylic sign by first peeling plastic protective sheets and mounting the LED light bar and chrome reflector strip.
3. Cut the LED cable roughly 8 inches from the light bar. Strip ends exposing the red and black wires.
4. Cutout white cardboard to fit within lid of project box. Start with a rectangle of the inner dimensions and then cutout arcs to provide room for the project box screw holes and the LED cable to pass through. White acrylic cut with a CO2 laser may also be used as shown in the example above.
5. Hot glue the assembled LED sign to the white cardboard cutout and allow to dry.
6. Mount the assembled LED sign with white cardboard into the project box lid. Hot glue the backside of the white cardboard to the lid. Ensure the LED cable has been passed through the backside of the cardboard to allow for connection.

Illuminated Laser Sign Build Instructions



Example: LED Lid Preparation – Front Side



Example: LED Lid Preparation – Back Side

Wiring:

1. As shown in the figure and example below, use a wire nut to connect the red wire from the 5V-12V step-up to the black 0 position lead of the toggle switch.

Illuminated Laser Sign Build Instructions

2. Using a wire nut, connect the red lead (1 position lead) of the toggle switch to the red or grey input wire of the 12V blinker module.
3. Connect the black output wire of the blinker module to the red input wire of the LED coming from the lid
4. Last, connect the black output wire from the LED to the black return wire of the 5V-12V step-up module.

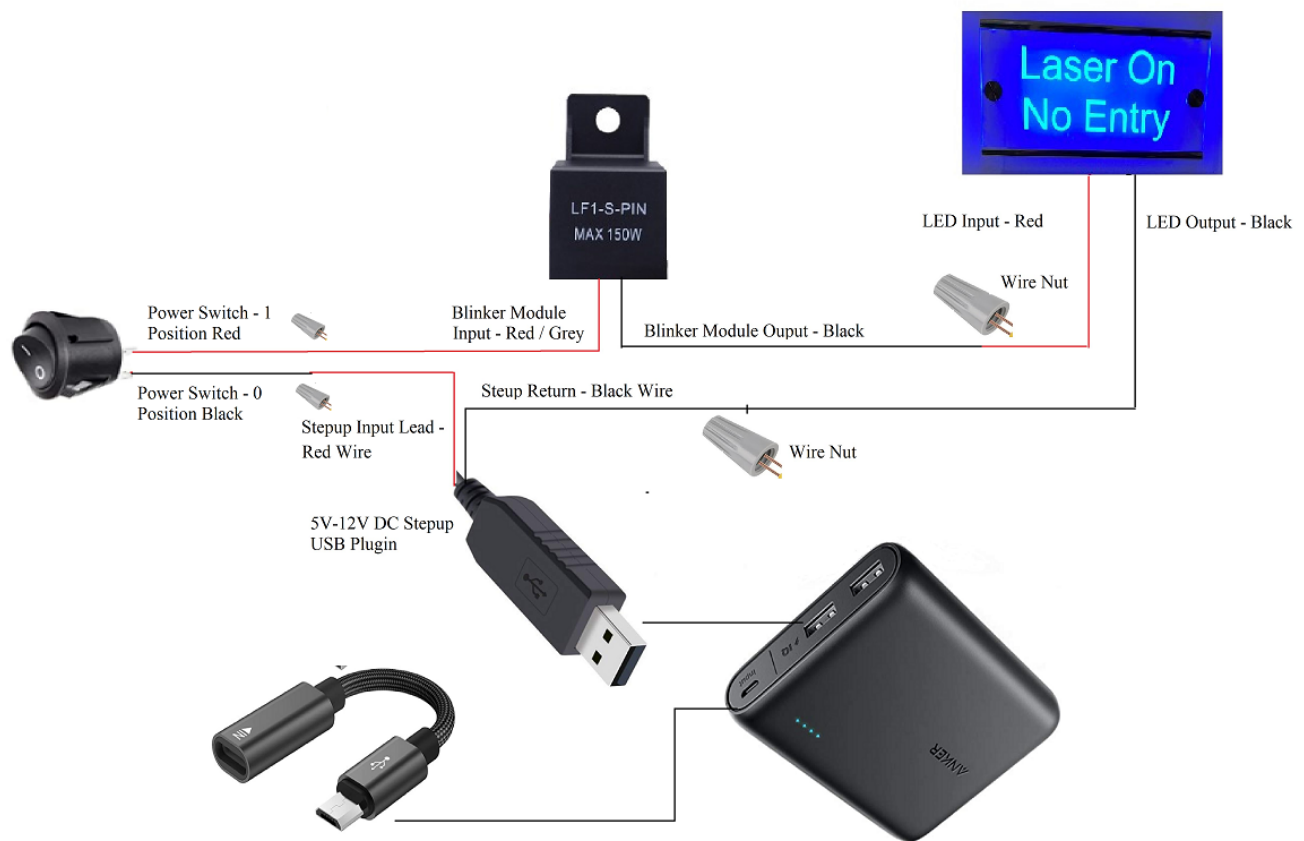
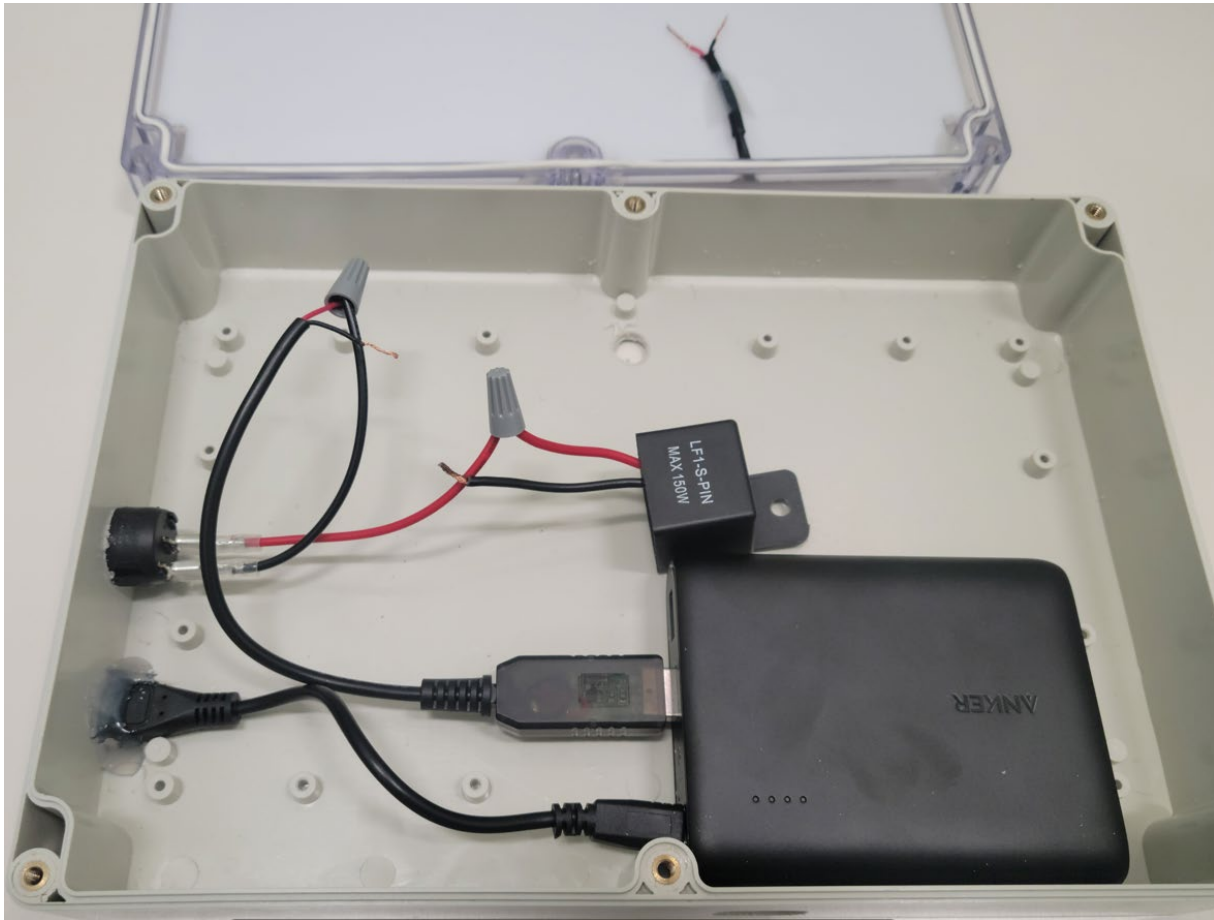

Figure 3: Battery Powered Sign Wiring Diagram

Illuminated Laser Sign Build Instructions



Example: Battery Powered Laser Sign Internal Wiring

5. Plug the micro USB charging cable into the micro USB port on the batter, then plug the 5V-12V step-up into the USB port.
6. With the lid still open, check for functionality by pressing the reset button on the battery, then switching the toggle to 'ON'.
7. If light works as intended, secure the lid with the provided 6 screws.

Illuminated Laser Sign Build Instructions

Appendix A: Standard Acrylic Sign Design



Illuminated Laser Sign Build Instructions

Appendix B: Enhanced Acrylic Sign Design

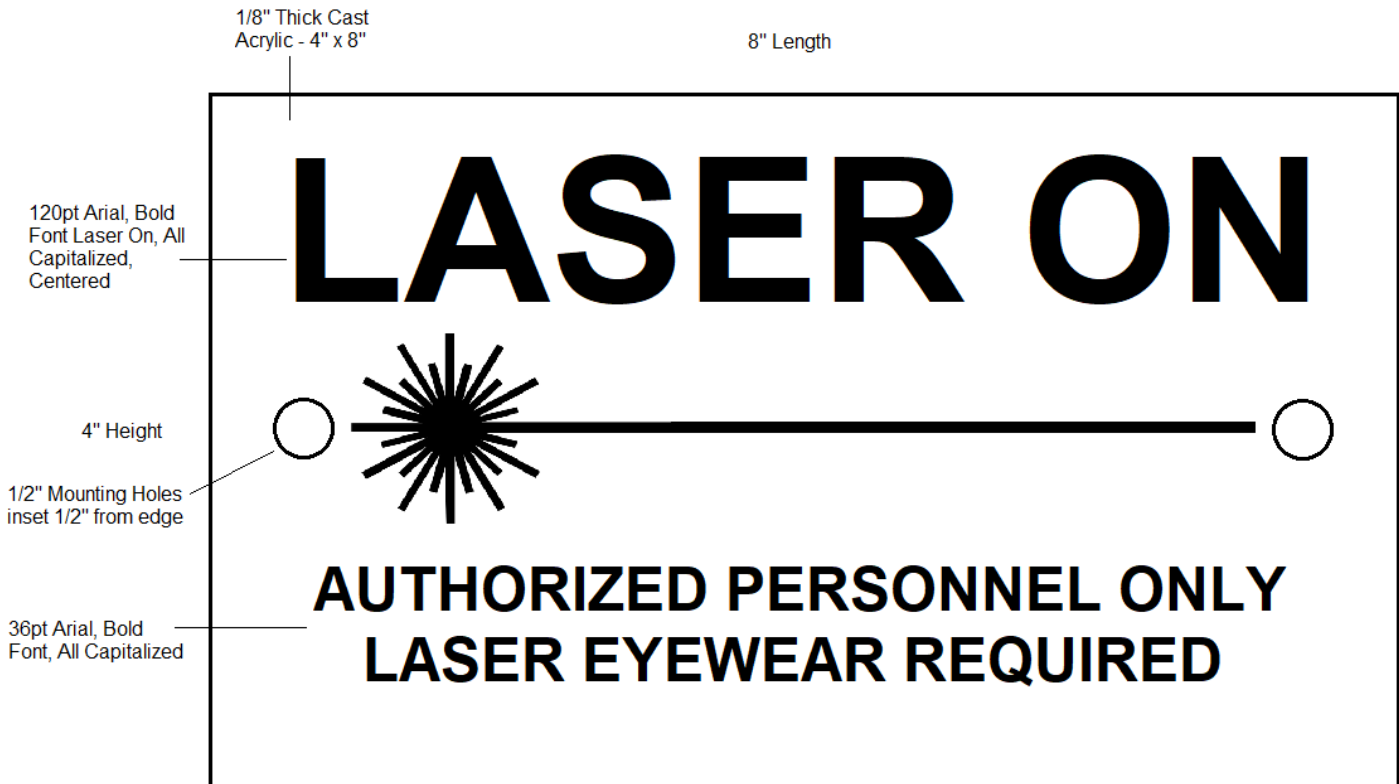

Illuminated Laser Sign Build Instructions

Appendix C: Alternative Adjustable 12V Blinker Module

DC 4.5-30V 10Amp Blinking Flasher Module, Normally Open

https://www.amazon.com/4-5-30V-10Amp-Blinking-Flasher-Module/dp/B095LDN44H/ref=sr_1_3?keywords=12v+blinker+module+adjustable&sr=8-3

