



The University of Texas at Austin

Project Management and Construction Services

Design and Construction Standards Technical Specification

SECTION 01 57 23

Temporary Storm Water Pollution Control

All renovation and new construction activities on The University of Texas at Austin campuses are required to meet the UT Austin Design and Construction Standards (DCS). This includes the very first planning and design stages through actual construction and facilities maintenance and management. They reflect the planning, design, construction, maintenance, and other facilities asset expertise of University personnel. These documents are to be used as a guideline on all UT Austin projects, and are not to be used for bidding, permitting, construction or any other purpose. Any deviations must be approved by the respective Division Champion, and will be submitted in writing by the Project Manager. The Design and Construction Standards are controlled by Project Management and Construction Services, The University of Texas at Austin. This document is the property of UT Austin, and use of this document, in part or in whole, for any purpose other than for a UT Austin project may not be done without written permission of the University.

For any comments or questions related to UT Austin Design and Construction Standards, please contact the Project Management and Construction Services Planning group at: campus_standards@austin.utexas.edu or by phone at (512) 471-0665.

The issuance and revision history of this Section is tabulated below. Please destroy any previous copy in your possession.

Rev Date	Pages	Remarks	Documents Referenced
6/5/2019	All	New Technical Specification created.	
1/31/2020	All	New Technical Specification published.	

TECHNICAL SPECIFICATION

01 57 23

1

1/31/2020

Temporary Storm Water Pollution Control REV 0 **SECTION 01 57 23 – TEMPORARY STORM WATER POLLUTION CONTROL**

(Note to PSP: Comply with requirements of authorities having jurisdiction and requirements established by the UT EHS Department. Coordinate with the UT Project Manager)

PART 1 - GENERAL

1.1 DEFINITIONS

- A. BMP – Best Management Practices
- B. CSN – Construction Site Notice (Large CSN for large sites; Small CSN for small sites)
- C. EHS – Environmental Health and Safety
- D. NOI and NOT – Notice of Intent and Notice of Termination for TPDES permits
- E. ODR – Owner Designated Representative
- F. Land Disturbance – Any activity which affects the ground surface and/or vegetation
- G. SWPPP – Storm Water Pollution Prevention Plan
- H. TCEQ – Texas Commission on Environmental Quality
- I. TPDES – Texas Pollutant Discharge Elimination System
- J. Large Construction Activities – Construction activities including clearing, grading and excavating that result in land disturbance equal to or greater than 5 acres of land. *(Note to PSP: Provide additional notes to the appropriate specification section or drawings as required.)*
- K. Small Construction Activities - Construction activities including clearing, grading and excavating that result in land disturbance equal to or greater than 1 acre and less than 5 acres of land. *(Note to PSP: Provide additional notes to the appropriate specification section or drawings as required.)*
- L. Under 1 Acre Construction Activities - Construction activities including clearing, grading, excavating, or any activity which affects the ground surface and/or vegetation that results in land disturbance under 1 acre of land *(Note to PSP: Include an Erosion Control & Sedimentation Plan as part of the construction documents. Prior to submission, coordinate with PMCS Project Manager & EHS as required.)*

1.2 RELATED DOCUMENTS AND APPLICABLE WORK

- A. The TCEQ TPDES Construction General Permit (CGP) No. TXR150000 effective March 5, 2018 and the project SWPPP. This specification requires compliance with all provisions of the TCEQ TPDES permit, the City of Austin Drainage Criteria Manual, and the City of Austin Environmental Criteria Manual. The TCEQ requirements currently pertain to large construction

SECTION 01 57 23

2

1/31/2020

Temporary Storm Water Pollution Control

REV 0

TECHNICAL SPECIFICATION

activities of 5 acres or more and small construction activities that disturb between 1 and 5 acres.
(*Note to PSP: Coordinate with UT EHS for guidance and recommendations.*)

- B. UT EH&S Construction Site
- C. Information to Respondents, Agreement, latest version of Uniform General Conditions, Additional General Conditions, and Special Conditions shall be read carefully for provisions pertaining to this work. In the event of conflict, the better quality shall prevail.
- D. The work described in this section is applicable to any and all sections of the contract documents. Any and all work that would disturb the existing site conditions or present the potential for site runoff shall adhere fully to this specification section.
- E. Unless specifically notified to the contrary in writing by the Owner, all aspects of this specification shall apply to this project.

1.3 CONTRACTOR RESPONSIBILITIES

- A. This project requires implementation of storm water Best Management Practices for control devices and monitoring by the Contractor to comply with all provisions of the SWPPP developed for the project by the licensed civil engineer. The Contractor must fulfill all TPDES regulatory requirements, including the filing of the NOI and NOT or signing and posting of the CSN.
- B. The Contractor shall provide signatures of a Corporate Officer for the NOI, Large CSN, Small CSN, NOT and any other forms or applications as required by the TPDES Construction General Permit TXR150000. The Contractor shall also provide delegated authorization to sign reports per 30 TAC 305.128. Individuals conducting site inspections shall be qualified to the satisfaction of the Owner. (*Note to PSP: Coordinate with UT EHS for guidance and recommendations.*)
- C. When the Contractor receives the approved SWPPP from the Owner, the Contractor signs and electronically files (through STEERS) the NOI, signs the Large or Small CSN and forwards it to the Owner. The application fee(s) must accompany the NOI. The Contractor shall insert a copy of the signed NOI or Small CSN into the SWPPP book to be kept at the jobsite. The application fee is not required for small construction sites. A copy of the NOI must be submitted to UT Austin EHS at EHS-EnvironmentalOps@austin.utexas.edu.
- D. The SWPPP book kept at the jobsite shall also contain the following:
 1. A letter delegating signature authority to the field personnel for the Contractor
 2. A copy of the TPDES permit when received
 3. A copy of the Large or Small CSN
 4. A copy of the Shared SWPPP Acceptance Certification form
 5. A copy of the SWPPP Project Start-Up form
- E. The Contractor shall review the SWPPP and verify existing conditions at the site before determining scope of implementation of site controls. Site survey and site plan drawings shall be used for additional reference. The Contractor shall notify the Owner, in advance, of this site review to allow for Owner and campus EHS participation.
- F. The Contractor shall construct a Project SWPPP sign and place it at the main entrance to the project site. This sign shall include the NOI and TPDES permit along with the TCEQ TPDES

TECHNICAL SPECIFICATION

Large or Small CSN, depending on the size of the construction project. The sign shall be constructed as detailed in the sample SWPPP sign drawing included in Part 4 of this Section.

- G. The Contractor shall contact the UT Austin project specific ODR and EHS for review of initial site controls in place prior to commencing site-disturbing activities, to ensure that any unusual circumstances or unforeseen site conditions with regard to erosion and sedimentation have been addressed. The Contractor, ODR, & EHS shall complete the SWPPP Project Start-up form and

shared SWPPP Acceptance Form before commencing soil disturbing activities. Both parties shall sign this form when the requirements listed in the SWPPP Project Start-up form have been met.

- H. The Contractor shall provide all material, labor, equipment and services required to implement, maintain and monitor all erosion and sedimentation controls in compliance with the SWPPP. All controls implemented by the Contractor shall comply with the TPDES regulations as issued by the TCEQ on March 5, 2018. These controls shall remain in operation until project completion and re-establishment of the site to pre-existing conditions (or improved) or longer as directed by the ODR. The work shall include, but not be limited to, the following:
1. All earthwork as required to implement swales, dikes, basins and other excavations for temporary routing of utilities, to protect against erosion or sediment-laden (polluted) storm water runoff.
 2. All structural controls as shown or specified, including silt fences, sediment traps, stabilized construction entrance, subsurface drains, pipe slope drains, inlet/outlet protection, reinforced soil retention, gabions, rock berms, etc.
 3. All non-structural controls as shown or specified, including temporary or permanent vegetation, mulching, geotextiles, sod stabilization, preservation of vegetative buffer strips, preservation/protection of existing trees and other mature vegetation.
 4. All modifications and revisions to SWPPP necessary to meet changing site conditions and to address new sources of storm water discharges, as the work progresses.
 5. All maintenance and repair of structural and non-structural controls in place shall continue until final stabilization is achieved or as directed by the ODR.
 6. Weekly site inspections, as required by the SWPPP, of pollutant sources, including hazardous sources, structural and non-structural controls, and all monitoring of SWPPP revisions and maintenance of inspection records.
 7. Removal of all structural and non-structural controls as necessary upon completion, and only after final stabilization is achieved.
 8. Filing of NOT with the ODR within 30 days of final stabilization being achieved and being approved by the Owner, or of another Operator assuming control of the unstabilized portions of the site.
 9. Refer to the SWPPP for additional requirements to ensure compliance with TPDES regulations.

1.4 QUALITY ASSURANCE

TECHNICAL SPECIFICATION

- A. In order to minimize the discharge of pollutants to storm water, the Contractor shall implement all permanent and temporary site controls according to TPDES Guidelines, as set forth by the TCEQ.
- B. Implementation of site controls shall be performed by a qualified contractor experienced in the proper installation of such devices in accordance with manufacturers' specifications, and in keeping with both recognized Best Management Practices (BMPs), and TPDES regulations.
- C. The Contractor shall inspect all BMPs at regular intervals as specified in the Storm Water Pollution Prevention Plan for this project. Use standard Owner Inspection forms for each inspection. Record all deficiencies of site controls, and take immediate action to correct any deficiencies recorded. Keep records of inspections current and on file, available for review by EPA, TCEQ, MS4 Operator and Owner.

1.5 SUBMITTALS

- A. Submittals of products used in structural and non-structural controls shall be made through established procedures prior to installation on the site. The Contractor shall make available physical samples and product literature on any material used in structural or non-structural controls during the course of the project prior to its implementation in the field.

PART 2 - PRODUCTS**2.1 MATERIALS**

Specific site control devices are identified in the SWPPP. Where such devices are indicated, their material composition shall comply with this section. Refer to exhibits for details of listed materials. Projects may propose alternative BMPs, as long as they are effective at performing the desired functions.

- A. Materials to be used in structural and non-structural site controls shall include, but not be limited to the following:
 1. **Area Inlets, Curb Inlets and Silt Fences:** implemented to filter and remove sediment from storm water; they shall be composed of the materials listed in Exhibit A, B, and C respectively.
 2. **Rock Berms:** shall be composed of the materials listed in Exhibit D:
 3. **Triangular Filter Dikes:** for use on surfaces or in locations where standard silt fence cannot be implemented. Refer to Exhibit E.
 4. **Mulch Sock:** shall be composed of the materials listed in Exhibit F
 5. **Stabilized Construction Exit:** allows the safe passage of vehicles while agitating the tires to loosen and remove the soil buildup. The grid or structures shall conform to the following:
 - a. Bull Rock and Cattle Guard (Exhibit G)
 - b. Bull Rock (Exhibit H)
 - c. Cattle Guard
 - 1) It shall consist of pipes or tubes spaced such that there is a minimum clear distance between the pipes or tubes of 4½ inches.
 - 2) Minimum diameter of pipe or tube shall be 3 inches.

TECHNICAL SPECIFICATION

- 3) It shall be of sufficient length so that the agitation will remove the soil from the tires, or a minimum of 12 feet.
 - 4) At the street side approach of the grid there shall be an impervious surface or it shall consist of 3" to 5" diameter angular crushed stone/rock approximately 5 feet in length, minimum, and 8 inches deep, minimum. On the job site side of the grid, there shall be 3" to 5" diameter angular crushed stone/rock 15 feet in length, a minimum of 8 inches deep. The steel grid will be between the street side approach and the job site crushed stone/rock. All crushed stone/rock shall have filter fabric beneath the stone/rock.
- d. Tracking Control Mat (Exhibit I or equivalent product)
- 6. **Concrete, Paint and Stucco Washout:** shall be used for containment of fluids from concrete truck washout wastes. Refer to Exhibit J. (Note to PSP: Provide location on the site plan.)
 - 7. **Temporary Storage Tanks:** shall be used for temporary storage of fuels on the construction project site. (Note to PSP: Provide location on the site plan.)
 - a. 2 inches of sand on the bottom of the containment area
 - b. 6 mil plastic sheeting
 - c. 2 inches of sand on top of the plastic sheeting
 - 8. **Diversion Dike:** Refer to Exhibit K.
 - 9. **Interceptor Swale:** Refer to Exhibit L.
 - 10. **Erosion Control Matting:** shall be used on steep slopes, in drainage swales, and in high traffic pedestrian areas of barren soil. It shall include one or more of the following
 - a. Jute Mat – a plain fabric made of jute yarn, woven in a loose and simple manner, with a minimum unit weight of 2.7 pounds per square yard. Width shall be as required for the dimensions of the area to be covered.
 - b. Wood Fiber Mat – a mat composed of wood fibers, which are encased in nylon, cotton or other type of netting
 - c. Synthetic Webbing Mat – a mat manufactured from polyvinyl chloride or polypropylene monofilaments, which are bonded together into a three-dimensional web to facilitate erosion control and/or re-vegetation.
 - 11. **Organic Mulches:** shall be used for covering bare soil, retaining moisture under existing vegetation being preserved, and for absorbing the energy of compaction caused by foot or vehicular traffic. Refer to Exhibit M.
 - 12. Any other materials indicated in the SWPPP.

PART 3 - EXECUTION**3.1 GENERAL**

- A. The Contractor shall provide a complete installation of all site control devices and measures (BMPs) indicated in the SWPPP book, including the Site Erosion and Sedimentation Control Drawing and as specified herein. These BMPs must be confirmed as fully operational with the Owner before any work that disturbs the site can begin.

TECHNICAL SPECIFICATION

As an alternative to the BMPs indicated in the SWPPP book, the Site Erosion and Sediment Control Drawing and as specified herein, the Contractor may propose alternate BMPs that perform the same function as the indicated BMP but may be of a different configuration, materials, or type for review and approval by UT Austin. Installation of alternate BMPs shall not proceed until reviewed and approved by UT EHS.

- B. The Contractor shall provide inspection and monitoring of controls in place and shall perform all revisions and updating of SWPPP book. An accurate, chronological record of all Contractor inspections, revisions and additional controls shall be kept on file at the project site, for review, with a copy of the SWPPP book.
- C. The Contractor shall submit their NOT to the Owner after all disturbed areas are re-established (stabilized) with vegetative cover following completion of construction. Following acceptance of stabilized areas, all site controls that are no longer necessary shall be removed.
- D. If applicable, contractor to follow the approved de-watering plan, either as included in the approved SWPPP or as a stand-alone plan in conjunction with the erosion and sedimentation control plan. *(Note to PSP: Provide a site specific de-watering plan during the design phase to EHS for review and comment.)*

3.2 CONTROL DEVICES

Execution of specific site control devices is described in the following paragraphs. Refer to the SWPPP for applicable devices, extent and location. Refer to exhibits for details on the execution of listed control devices. *(Note to PSP: Review UT EHS website for Best Management Practices (BMPs) for your project and coordinate with EHS personnel prior to including necessary requirements.)*

- A. AREA INLET: Refer to Exhibit A. B.
- CURB INLET: Refer to Exhibit B.
- C. SILT FENCE: Refer to Exhibit C.
- D. ROCK BERM: Refer to Exhibit D.
- E. TRIANGULAR FILTER DIKE: Refer to Exhibit E
- F. MULCH SOCK: Refer to Exhibit F.
- G. STABILIZED CONSTRUCTION EXIT: The stabilized construction exit shall be properly maintained throughout the entire construction process until removal is approved by UT Austin.
 - 1. Bull Rock and Cattle Guard (Exhibit G)
 - 2. Bull Rock (Exhibit H)
 - 3. Cattle Guard
 - a. It shall be elevated above the ground surface a minimum of 8 inches to allow water, debris and soil to drain.
 - b. It shall be designed to support any and all vehicles entering and leaving the construction site.
 - c. It shall be firmly placed in the ground at the exit.

TECHNICAL SPECIFICATION

- d. Steel grid area shall be used as the tire wash area. When tire wash is in use (rainy or muddy days), the area shall be manned and the tires shall be washed using a high pressure hose/nozzle.
 - e. The area beneath the grid shall be sloped such that debris, soil and water shall be diverted back onto the construction site or to a sediment basin. No water, soil, or debris shall leave the construction site. The resulting discharge shall be disposed of properly.
 - f. The stabilized construction exit shall be properly maintained throughout the entire construction process until removal is approved by UT Austin
4. Tracking Control Mat (Exhibit I or equivalent product)
- H. CONCRETE/PAINT/STUCCO WASHOUT (SELF INSTALLED): Refer to Exhibit J.
- I. TEMPORARY STORAGE TANKS
1. Must be located in a bermed containment area. The berm must be a minimum 3 feet in all directions, and the height of the berm must contain the maximum contents of the largest tank plus 8 inches (approximately 110% of the tank capacity). The containment area is constructed by beginning with a 2-inch sand pad, and then covered with 6-mil plastic or rubber sheeting. The sheeting is then covered with another 2-inch layer of sand. The plastic sheeting is secured to the outer berm.
 2. Storage tanks are to be placed no closer than 50 feet from a building or property line.
 3. If using tanks with a gravity feed setup, the containment must be of sufficient size to be able to contain the tank if it should fall over.
 4. There must be a fusible link at the valve that will shut off the flow to the hose in the event of a fire.
 5. There must be sufficient cover for the tank and the containment area to prevent potential storm water runoff.
 6. The area within the containment area is to be kept free and clear of spills; if a spill occurs, the sand is to be removed and replace with a fresh layer of sand.
 7. The storage tank containment area is to be removed from the site once it has been determined that it will no longer be used on the construction site.
- J. DIVERSION DIKE:
Refer to Exhibit K.
- K. INTERCEPTOR SWALE: Refer to Exhibit L.
- L. EROSION CONTROL MATTING
1. Remove all rocks, debris, dirt clods, roots, and any other obstructions which would prevent the matting from lying in direct contact with the soil. 6 inch by 6-inch anchor trenches shall be dug along the entire perimeter of the installation. Bury matting in trenches, backfill and compact. Fasten matting to the soil using 10-gauge wire staples, 6 inches in length and 1 inch wide. Use a minimum of 1 staple per 4 square feet of matting, and at 12 inches on center along all edges. Install parallel to flow of water and overlap joining strips a minimum of 12 inches.
 2. Maintain erosion control matting by repairing any bare spots. Missing or loosened matting shall be promptly replaced or re-anchored.

TECHNICAL SPECIFICATION

3. Remove matting where protection is no longer required. In areas where permanent vegetation is established along with matting, matting can be left in place permanently.

M. ORGANIC MULCHES

1. Apply specified mulches in areas identified on the SWPPP, to a depth of 3 inches or as otherwise specified on the SWPPP drawings. Refer to Exhibit M.

N. BMP Details

1. Refer to Exhibits for the following BMP details:

Exhibit A -- Area Inlet Detail

Exhibit B -- Curb Inlet Detail

Exhibit C -- Silt Fence Detail

Exhibit D -- Rock Berm Detail

Exhibit E -- Triangular Filter Dike Detail

Exhibit F -- Mulch Sock Detail

Exhibit G -- Stabilized Construction Exit -- Bull Rock and Cattle Guard Detail

Exhibit H -- Stabilized Construction Exit -- Bull Rock Detail

Exhibit I -- Stabilized Construction Exit -- Tracking Control Mat Detail

Exhibit J -- Concrete, Paint and Stucco Washout Detail

Exhibit K -- Diversion Dike Detail

Exhibit L -- Interceptor Swale Detail

Exhibit M -- Organic Mulches Detail

3.3 INSPECTIONS AND RECORD KEEPING

- A. Contractor shall inspect all BMPs on 7-day intervals. Coordinate inspections with ODR, who is also required by TPDES to regularly inspect the site. Use standard Owner Inspection forms for each inspection. Record all deficiencies of site controls, and take appropriate action to correct any deficiencies recorded. Exception is rock berms located in a streambed. Any rock berm located in a streambed shall be inspected on a daily basis.
- B. Contractor shall accommodate the monthly (at minimum) inspections of SWPPP controls by EHS as the MS4 Authority Having Jurisdiction (AHJ).
- C. Contractor shall keep records of all Contractor, ODR, and EHS inspections on file with SWPPP book at project site for the duration of the project. Contractor shall keep records of all major grading and stabilization activities on file with the SWPPP book at the project site for the duration of the project. These records shall be made available for review by ODR, EPA, TCEQ or MS4 Operator officials requesting review of SWPPP inspection records.

TECHNICAL SPECIFICATION

- D. All onsite SWPPP records shall be submitted to the ODR at the project completion. The ODR must submit these records to EHS. EHS will keep these on file for 3 years per TCEQ regulations.

3.4 MAINTENANCE

- A. All erosion and sediment control measures and other protective measures identified in the SWPPP must be maintained in effective operating condition. If through inspections the permittee determines that BMPs are not operating effectively, maintenance must be performed before the next anticipated storm event or as necessary to maintain the continued effectiveness of storm water controls. If maintenance prior to the next anticipated storm event is impracticable, maintenance must be scheduled and accomplished as soon as practicable. Erosion and sediment controls that have been intentionally disabled, run over, removed or otherwise rendered ineffective must be replaced or corrected immediately upon discovery.

3.5 WASTE DISPOSAL

- A. Contractor is responsible for proper disposal of hazardous materials. Hazardous wastes (such as flammable petroleum products and solvents, thinners) and materials contaminated with hazardous wastes are considered regulated wastes, and should be containerized for transport and disposal by a permitted company in accordance with applicable laws and regulations.
- B. Any trash or debris must be contained on site and disposed of in a recycling bin or waste receptacle in accordance with applicable laws and regulations to prevent wind or rain from carrying it off-site into a storm drain. Non-hazardous solid wastes such as general construction debris may be recycled or disposed of in the trash container. Never dispose of liquid wastes of any kind in University dumpsters.
- C. Contractor to remove all temporary control measures from the project site.

PART 4 - SAMPLE DOCUMENTS**4.1 THE FOLLOWING FORMS OR SKETCHES ARE TO BE USED BY THE CONTRACTOR IN THE EXECUTION OF THE WORK IN THIS SECTION, IN COMPLIANCE WITH TPDES REQUIREMENTS AND THE SWPPP.**

- A. SWPPP Posting Sign for Main Construction Entrance for large construction site 5 acres or greater.
- B. SWPPP Posting Sign for Main Construction Entrance for small construction site 1 to less than 5 acres.
- C. Sketches in Exhibit A through M.

4.2 CONTACT THE ODR FOR ELECTRONIC COPIES OF THESE FORMS TO BE USED IN THE EXECUTION OF WORK IN THIS SECTION:

- A. TCEQ TPDES Notice of Intent (NOI)
- B. TCEQ TPDES CSN (Large CSN or Small CSN)
- C. TCEQ TPDES Notice of Termination (NOT)
- D. Shared SWPPP Acceptance Certification form
- E. SWPPP Project Start-up Form

- F. Major Grading and Stabilization Log
- G. SWPPP Inspection form

END OF SECTION 01 57 23

Sign for Large Construction Site

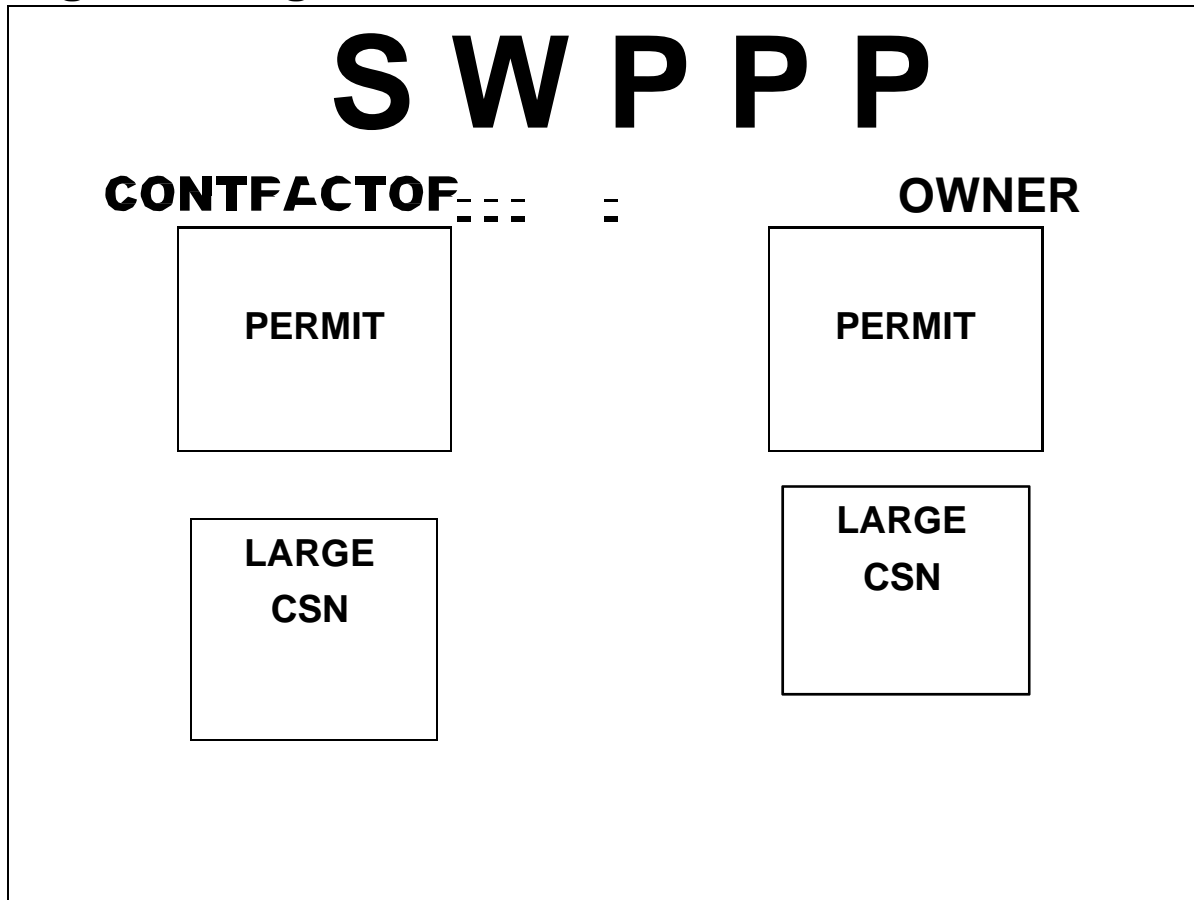

MINIMUM SIGN SPECIFICATIONS: 5 Acre or Greater Sites

SIGN: Exterior grade 3/4" plywood, cut 4' x 4', with red painted letters, background painted white – DISPLAY ON CONSTRUCTION FENCE AT MAIN ENTRANCE TO PROJECT SITE.

S W P P P: 10-inch painted letters, 3 inches from top of sign, centered

CONTRACTOR OWNER: 3 inch painted letters, 4 inches below SWPPP letters, centered on each half of sign

PERMIT, CSN: 8-1/2 X 11 TCEQ forms, laminated beyond edges of documents, stapled to plywood.

Sign for Small Construction Site

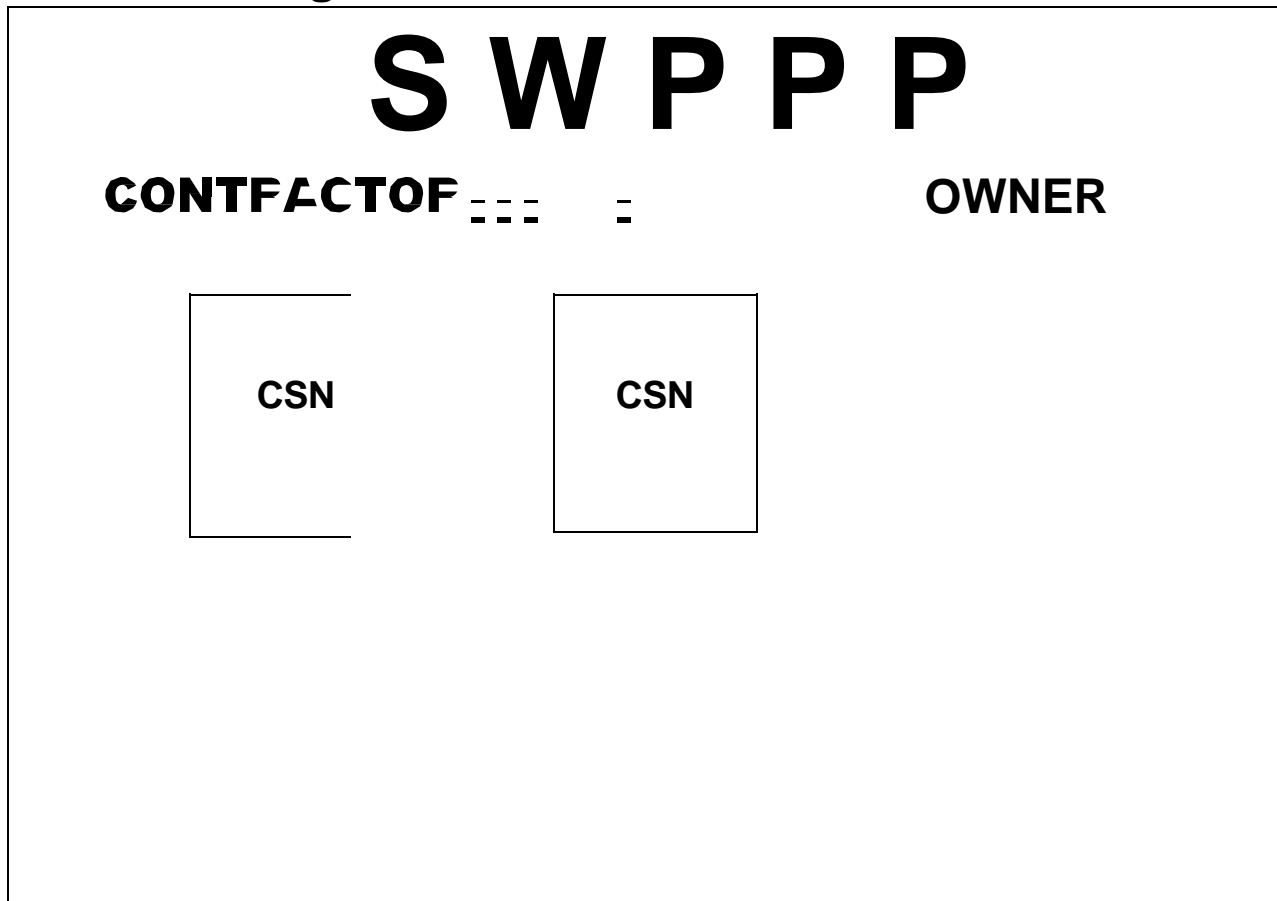

MINIMUM SIGN SPECIFICATIONS: 1 to Less than 5 Acre Sites

SIGN: Exterior grade 3/4-inch plywood, cut 4' x 4', with red painted letters, background painted white -

DISPLAY ON CONSTRUCTION FENCE AT MAIN ENTRANCE TO PROJECT SITE

S W P P P: 10-inch painted letters, 3 inches from top of sign, centered

TECHNICAL SPECIFICATION **The University of Texas at Austin**

CONTRACTOR OWNER: 3-inch painted letters, 4 inches below SWPPP letters, centered on each half of sign

CONSTRUCTION SITE NOTICE: 8-1/2-inch X 11-inch TCEQ forms, laminated beyond edges of documents, stapled to plywood

TECHNICAL SPECIFICATION

EXHIBIT A Area Inlet Detail

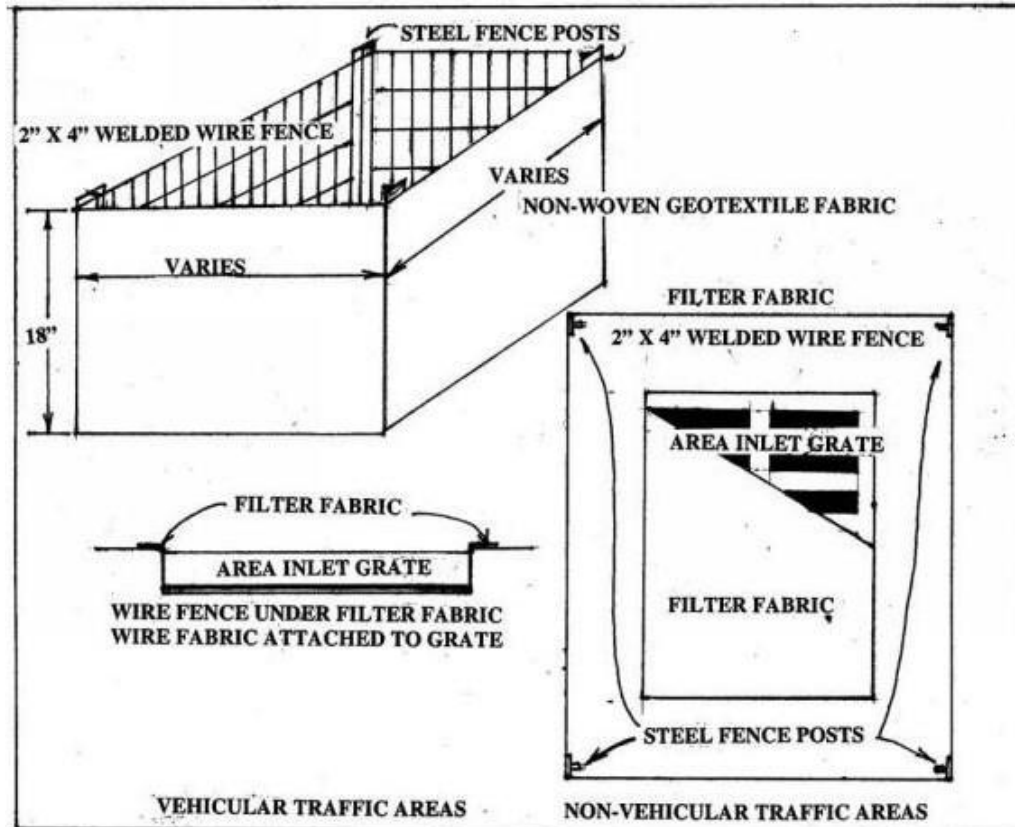

Notes:

1. INSTALL STEEL POSTS THAT SUPPORT THE SILT FENCE AT EACH CORNER, AND ALSO BETWEEN CORNERS IF THE DISTANCE IS GREATER THAN 8 FEET BETWEEN CORNER POSTS.
2. USE SILT FENCE DETAIL FOR INSTALLATION OF THE SILT FENCE AROUND THE AREA INLET.
3. LIFT THE METAL AREA INLET GRATE, WRAP THE FILTER FABRIC AROUND IT, AND THEN REPLACE THE GRATE.
4. IN VEHICULAR TRAFFIC AREAS, LIFT THE METAL GRATE OUT AND PLACE WIRE FENCE MATERIAL UNDER IT WITH FILTER FABRIC PLACED BETWEEN THE GRATE AND THE WIRE FENCE. THEN ATTACH THE WIRE FENCE TO THE GRATE.
5. REMOVE ACCUMULATED SILT WHEN THE FILTER FABRIC OVER THE GRATE COMPLETELY COVERS THE GRATE AREA AND THE SILT AROUND THE SILT FENCE REACHES A HEIGHT OF 6 INCHES.
6. REMOVE AREA INLET PROTECTION WHEN THE SITE IS COMPLETELY STABILIZED.

Materials:

TECHNICAL SPECIFICATION

1. Geotextile fabric – a non-woven, polypropylene, polyethylene, or polyamide fabric with non-raveling edges. It shall be non-biodegradable, inert to most soil chemicals, ultraviolet resistant, unaffected by moisture and other weather conditions, and permeable to water while retaining sediment. Fabric shall be 36 inches wide, with a minimum weight of 4.5 oz./yd.
2. Wire Backing – a galvanized, 2"x4" welded wire fencing, 12.5-gauge minimum. Width shall be sufficient to support geotextile fabric 24 inches above adjacent grades. Chain link fences located along the same lines as silt fences may be used to support geotextile fabric. In this circumstance, the geotextile fabric shall be firmly attached to the fence.
3. Posts for area inlets and silt fences – steel fence posts shall be made of hot rolled steel, galvanized or painted, and installed per detail, with a Y-bar or TEE cross-section of sufficient strength to withstand forces implied.

Execution:

1. Area inlet fences shall consist of non-woven geotextile fabric attached to wire fabric backing to support the geotextile. Attach non-woven geotextile fabric to the fence with hog rings or standard cable/wire ties, leaving a toe of fabric at the bottom of the fence of not less than 6 inches. Steel posts as specified shall be driven to a depth of 1-foot minimum and spaced not more than 8 feet on center. Attach fencing to posts with standard cable/wire ties. Abutting ends of geotextile fabric shall be overlapped a minimum of 12 inches. Wrap grates with non-woven geotextile fabric.
2. Maintain silt fence daily as necessary to repair breaches in geotextile fabric. Maintain steel posts as specified in tilted condition. When siltation has occurred, it shall be removed when it has reached a depth of 6 inches. Silt that has been removed shall be disposed of offsite.
3. Remove area inlet when the disturbed areas have been completely stabilized as specified. Minimize land disturbance while removing area inlet protection and posts.

TECHNICAL SPECIFICATION

EXHIBIT B Curb Inlet Detail

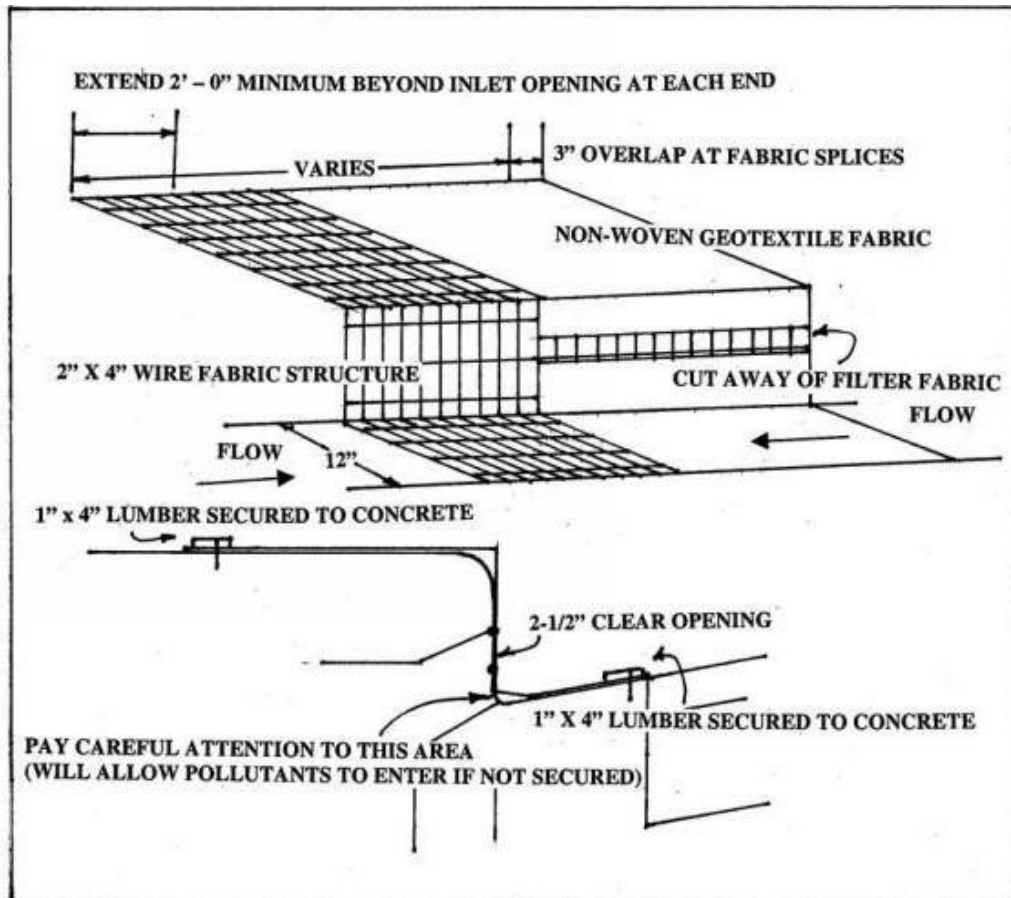

NOTES:

1. WHERE MINIMUM CLEARANCES CAUSE TRAFFIC TO DRIVE IN THE GUTTER, USE 1" BY 4" LUMBER SECURED WITH CONCRETE NAILS 3 FEET ON CENTER NAILED INTO THE CONCRETE. IF THERE IS PEDESTRIAN TRAFFIC ONLY, THE USE OF 20 LB. GRAVEL BAGS TO SECURE MATERIAL IS PERMITTED.
2. REMOVE SECTION OF FILTER FABRIC AS SHOWN IN THIS DETAIL. SECURE FABRIC TO WIRE BACKING WITH CLIPS OR HOG RINGS AT THIS LOCATION.
3. INSPECT DAILY AND REMOVE SILT ACCUMULATION WHEN THE DEPTH REACHES 2 INCHES.
4. MONITOR THE PERFORMANCE OF THE INLET PROTECTION DURING EACH RAINFALL EVENT AND REMOVE PROTECTION IMMEDIATELY IF THE STORM WATER BEGINS TO OVERTOP THE CURB.
5. REMOVE INLET PROTECTION AS SOON AS THE SOURCE OF SEDIMENT IS STABILIZED.

Materials:

TECHNICAL SPECIFICATION

1. Geotextile fabric – a non-woven, polypropylene, polyethylene, or polyamide fabric with non- raveling edges. It shall be non- biodegradable, inert to most soil chemicals, ultraviolet resistant, unaffected by moisture and other weather conditions, and permeable to water while retaining sediment. Fabric shall be 36 inches wide, with a minimum weight of 4.5 oz./yd.
2. Wire Backing – a galvanized, 2"x4" welded wire fencing, 12.5 -gauge minimum.

Execution:

1. Cover curb storm inlet with non-woven geotextile fabric covered wire backing. Extend fabric 2 feet beyond inlet opening at each end and 12 inches in front of opening in the gutter. Remove 2.5" strip of filter fabric near the top of the inlet for the length of the protection to act as overflow. Extend fabric over the top of opening to allow placement of gravel bags. Anchor fabric with 20 lb. gravel bags placed 3 feet on center.
2. Maintain inlet protection daily as necessary to repair breaches in geotextile fabric. When siltation has occurred, it shall be removed when it has reached a depth of 2 inches. Silt that has been removed shall be disposed of offsite.

TECHNICAL SPECIFICATION

EXHIBIT C Silt Fence Detail

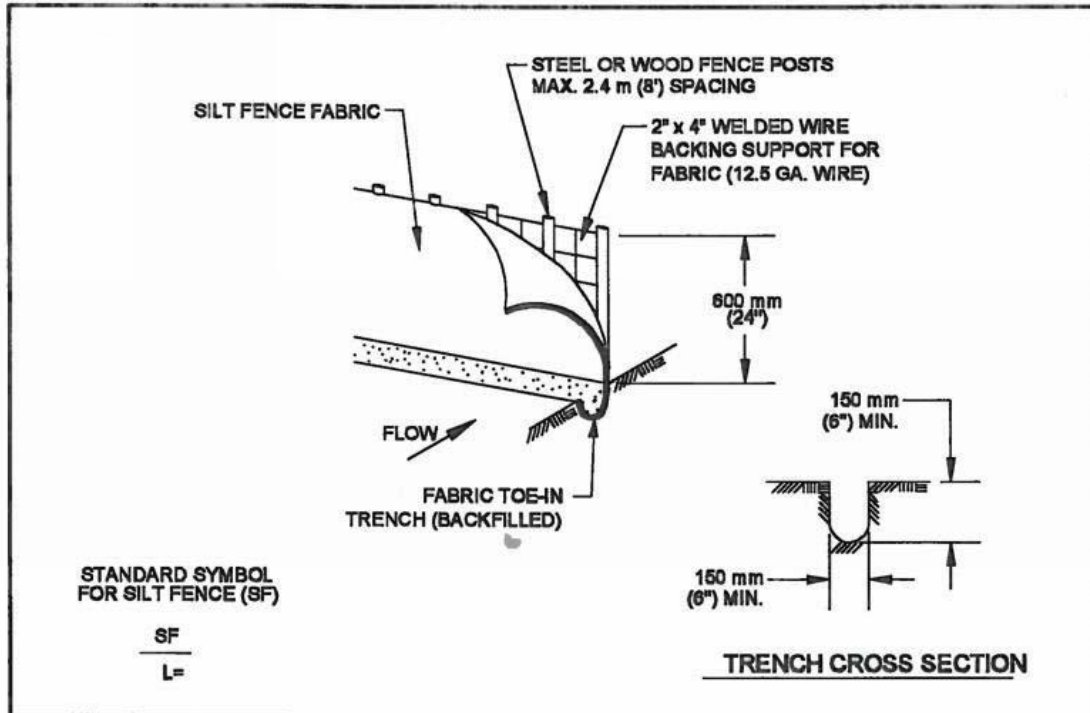

1. STEEL OR WOOD POSTS WHICH SUPPORT THE SILT FENCE SHALL BE INSTALLED ON A SLIGHT ANGLE TOWARD THE ANTICIPATED RUNOFF SOURCE. POST MUST BE EMBEDDED A MINIMUM OF 300 mm (12 INCHES). IF WOOD POSTS CANNOT ACHIEVE 300 mm (12 INCHES) DEPTH, USE STEEL POSTS.
2. THE TOE OF THE SILT FENCE SHALL BE TRENCHED IN WITH A SPADE OR MECHANICAL TRENCHER, SO THAT THE DOWNSLOPE FACE OF THE TRENCH IS FLAT AND PERPENDICULAR TO THE LINE OF FLOW.
3. THE TRENCH MUST BE A MINIMUM OF 150 mm (6 INCHES) DEEP AND 150 mm (6 INCHES) WIDE TO ALLOW FOR THE SILT FENCE FABRIC TO BE LAID IN THE GROUND AND BACKFILLED WITH COMPACTED MATERIAL.
4. SILT FENCE FABRIC SHOULD BE SECURELY FASTENED TO EACH STEEL OR WOOD SUPPORT POST OR TO WOVEN WIRE, WHICH IS IN TURN ATTACHED TO THE STEEL OR WOOD FENCE POST.
5. INSPECTION SHALL BE MADE WEEKLY OR AFTER EACH RAINFALL EVENT AND REPAIR OR REPLACEMENT SHALL BE MADE PROMPTLY AS NEEDED.
6. SILT FENCE SHALL BE REMOVED WHEN THE SITE IS COMPLETELY STABILIZED SO AS NOT TO BLOCK OR IMPEDE STORM FLOW OR DRAINAGE.
7. ACCUMULATED SILT SHALL BE REMOVED WHEN IT REACHES A DEPTH OF 150 mm (6 INCHES). THE SILT SHALL BE DISPOSED OF ON AN APPROVED SITE AND IN SUCH A MANNER THAT WILL NOT CONTRIBUTE TO ADDITIONAL SILTATION.

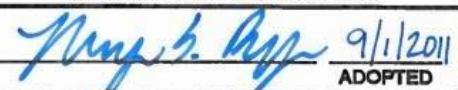
CITY OF AUSTIN WATERSHED PROTECTION DEPARTMENT		SILT FENCE	
 9/1/2011 ADOPTED		THE ARCHITECT/ENGINEER ASSUMES RESPONSIBILITY FOR APPROPRIATE USE OF THIS STANDARD.	STANDARD NO. 642S-1

TECHNICAL SPECIFICATION**Materials:**

1. Geotextile fabric – a non-woven, polypropylene, polyethylene, or polyamide fabric with non-raveling edges. It shall be non-biodegradable, inert to most soil chemicals, ultraviolet resistant, unaffected by moisture and other weather conditions, and permeable to water while retaining sediment. Fabric shall be 36 inches wide, with a minimum weight of 4.5 oz./yd.
2. Wire Backing – a galvanized, 2"x4" welded wire fencing, 12.5-gauge minimum. Width shall be sufficient to support geotextile fabric 24 inches above adjacent grades. Chain link fences located along the same lines as silt fences may be used to support geotextile fabric. In this circumstance, the geotextile fabric shall be firmly attached to the fence.
3. Posts for area inlets and silt fences – steel fence posts shall be made of hot rolled steel, galvanized or painted, and installed per detail, with a Y-bar or TEE cross-section of sufficient strength to withstand forces implied.

Execution:

1. Silt fences shall consist of non-woven geotextile fabric, attached to wire fabric backing to support the geotextile. Attach non-woven geotextile fabric to fence with hog rings or standard cable/wire ties, leaving a toe of fabric at the bottom of the fence of not less than 6 inches. Steel posts as specified shall be driven to a depth of 1-foot minimum and spaced not more than 8 feet on center. Tilt posts slightly, in an uphill direction for additional strength. Attach fencing to posts with standard cable/wire ties. Dig a 6-inch deep by 6-inch wide trench on the disturbed side of the fence, bury geotextile fabric in trench, backfill and tamp. Abutting ends of geotextile fabric shall be overlapped.
2. Maintain silt fence daily as necessary to repair breaches in geotextile fabric. Maintain steel posts as specified in tilted condition. When siltation has occurred, it shall be removed when it has reached a depth of 6 inches. Silt that has been removed shall be disposed of offsite.
3. Remove silt fence when the disturbed areas protected by silt fence have been completely stabilized as specified. Minimize land disturbance while removing silt fence and posts.

TECHNICAL SPECIFICATION

EXHIBIT D Rock Berm Detail

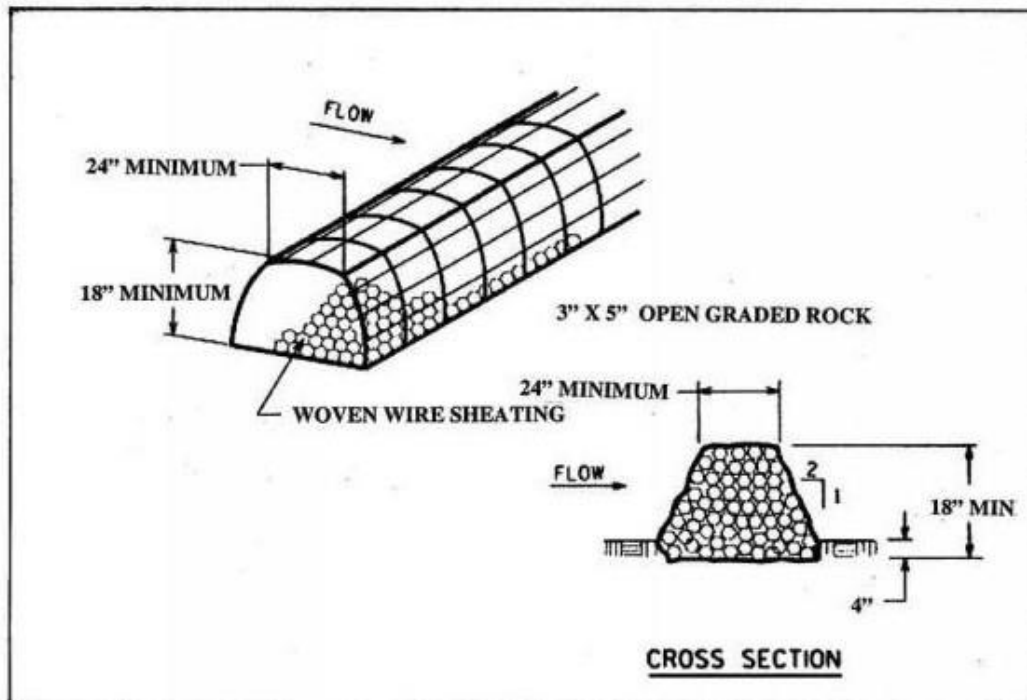

NOTES:

1. USE ONLY OPEN GRADED 4" X 8" ROCK FOR STREAM FLOW CONDITIONS. USE 3" X 5" OPEN GRADED ROCK FOR OTHER CONDITIONS.
2. SECURE THE ROCK BERM WITH A WOVEN WIRE SHEATHING HAVING A MAXIMUM 1 INCH OPENING AND A MINIMUM 20-GAUGE WIRE DIAMETER. ANCHOR ROCK BERMS IN CHANNEL APPLICATIONS FIRMLY INTO THE SUBSTRATE A MINIMUM OF 6 INCHES WITH TEE POSTS OR WITH #5 OR #6 REBAR WITH A MAXIMUM SPACING OF 48 INCHES ON CENTER.
3. INSPECT THE ROCK BERM WEEKLY. REPLACE THE STONE AND/OR FABRIC CORE-WOVEN SHEATHING WHEN THE STRUCTURE CEASES TO FUNCTION AS INTENDED DUE TO SILT ACCUMULATION AMONG THE ROCKS, WASHOUT, CONSTRUCTION TRAFFIC, ETC.
4. WHEN SILT REACHES A DEPTH EQUAL TO ONE-THIRD THE HEIGHT OF THE BERM OR 6 INCHES, WHICHEVER IS LESS, REMOVE THE SILT AND DISPOSE OF ON AN APPROVED SITE AND IN A MANNER THAT WILL NOT CREATE A SILTRATION PROBLEM.
5. INSPECT SEVERE SERVICE ROCK BERMS DAILY, AND REMOVE SILT WHEN ACCUMULATION REACHES 6 INCHES.
6. WHEN THE SITE IS COMPLETELY STABILIZED, REMOVE THE ROCK BERM AND ACCUMULATED SILT AND DISPOSE OF IN AN APPROVED MANNER.

Materials:

TECHNICAL SPECIFICATION

1. Rock – clean open graded rock. Use open graded 4" X 8" rock for stream flow conditions. Use 3" X 5" open graded rock for other conditions.
2. Wire Mesh Support – a galvanized, woven wire sheathing having a maximum opening size of 1 inch, and a minimum wire diameter of 20 gauge
3. Ties – metal hog rings or standard wire/cable ties. No plastic ties.

Execution:

1. Rock berm shall consist of rip-rap type rock, secured within a wire sheathing as specified, and installed at the toe of slopes, or at the perimeter of developing or disturbed areas. Height of berm shall be a minimum of 18 inches from top of berm to uphill toe of berm. Top width shall be a minimum of 24 inches, with side slopes of 2:1 or flatter. Uphill toe of berm shall be buried a minimum of 4 inches into existing grade. Rock berm shall have a minimum flow-through rate of 60 gallons per minute per square foot of berm face.
2. Maintain rock berm in a condition that allows the sediment to be removed, when the depth of sediment has reached 1/3 the height of the berm. Berm shall be reshaped as needed, and silt buildup removed, to maintain specified flow through berm.
3. Rock berm shall be removed when the disturbed areas served have been stabilized as specified

TECHNICAL SPECIFICATION

EXHIBIT E Triangular Filter Dike Detail

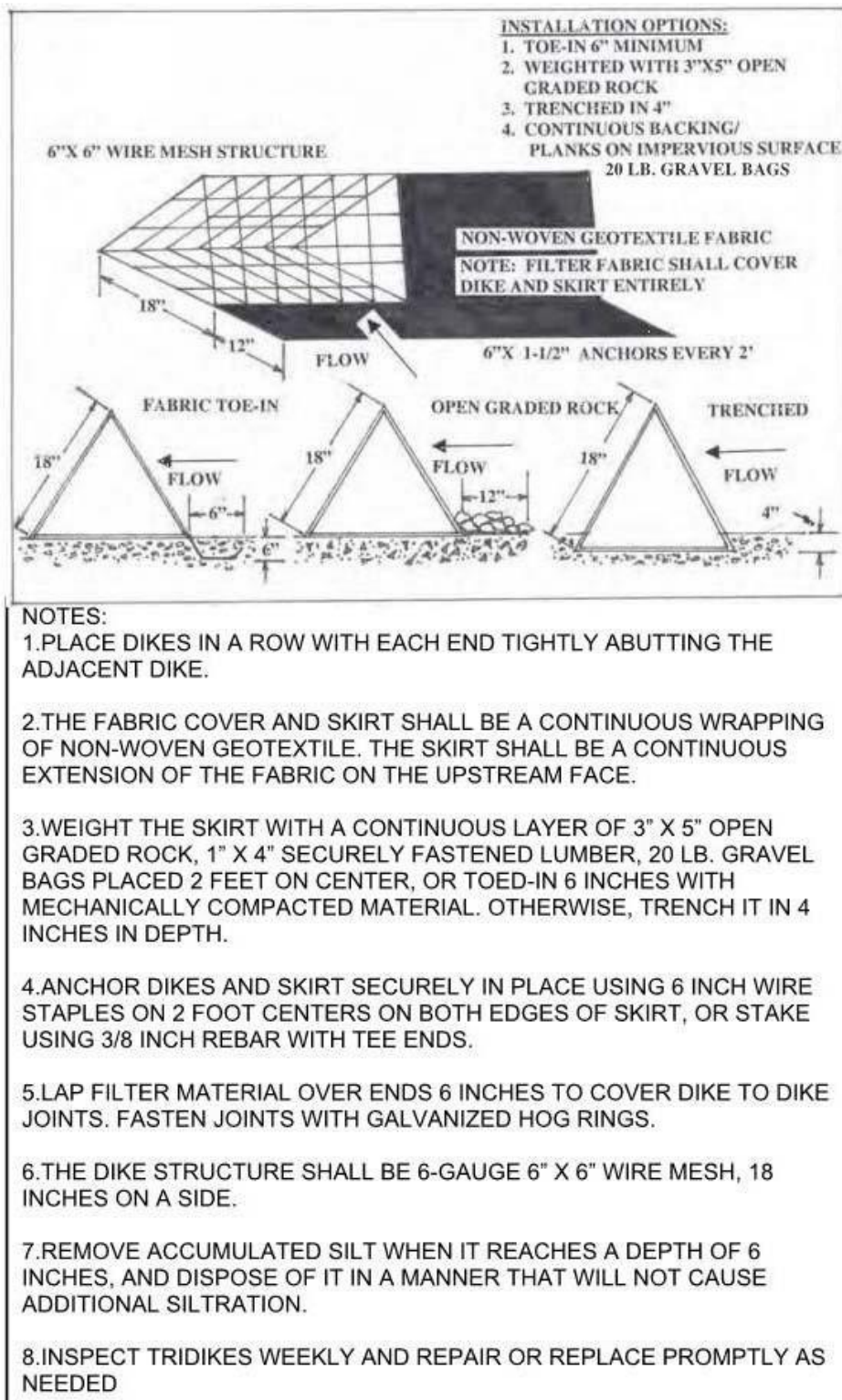

TECHNICAL SPECIFICATION

Materials:

1. Geotextile fabric – a non-woven, polypropylene, polyethylene, or polyamide fabric with nonraveling edges, with a minimum width of 60 inches
2. Dike Structure – 6-gauge, 6" x 6" welded wire mesh, 60 inches wide, folded into a triangular form. Each side shall be 18 inches with an overlap of 6 inches
3. Ties – metal hog rings or standard wire/cable ties for attachment of wire mesh to itself, and for attachment of geotextile fabric to wire mesh

Execution:

1. Filters shall be placed with ends tightly abutting the adjacent filter. Each filter and skirt shall be securely anchored in place using 6 inch staples on 2 foot centers.
2. Anchoring on impervious areas shall be accomplished with gravel bags placed at 2 feet on center or with a nominal 1" X 4" board nailed at 2 feet on center.
3. Silt accumulation behind triangular filter dikes shall be removed at a maximum depth of 6 inches or when the structure ceases to work as intended.
4. After completion of construction, the dike shall be removed and the site re-graded to the final grades. Any depression shall be filled and any accumulation of silt shall be spread or removed to a permitted disposal area.

TECHNICAL SPECIFICATION

EXHIBIT F Mulch Sock Detail

MULCH SOCK MATERIAL

USE UNTREATED WOOD CHIPS PRODUCED FROM A 3 (THREE) INCH MINUS SCREENING PROCESS (EQUIVALENT TO TXDOT ITEM 181, COMPOST, SECTION 1.6.2.B, WOOD CHIP REQUIREMENTS).

MULCH CONSISTS PRIMARILY OF ORGANIC MATERIAL, SEPARATED AT THE POINT OF GENERATION, AND MAY INCLUDE: SHREDDED BARK, STUMP GRINDINGS, OR COMPOSTED BARK.

LARGE PORTIONS OF SILT, CLAYS, OR FINE SANDS ARE NOT ACCEPTABLE IN THE MULCH.

NOTES:

1. STEEL OR WOOD POSTS WHICH SUPPORT THE MULCH SOCK SHALL BE INSTALLED ON A SLIGHT ANGLE TOWARD THE ANTICIPATED RUNOFF SOURCE. POST MUST BE EMBEDDED A MINIMUM OF 600mm (24 inches). IF WOOD POSTS CANNOT ACHIEVE 600mm (24 inches) DEPTH, USE STEEL POSTS. EARTH ANCHORS ARE ALSO ACCEPTABLE.
2. THE TOE OF THE MULCH SOCK SHALL BE PLACED SO THAT THE MULCH SOCK IS FLAT AND PERPENDICULAR TO THE LINE OF FLOW. IN ORDER TO PREVENT WATER FROM FLOWING BETWEEN THE JOINTS OF ADJACENT ENDS OF MULCH SOCKS, LAP THE ENDS OF ADJACENT MULCH SOCKS A MINIMUM OF 300mm (12 inches).
3. MULCH MATERIAL MUST BE FREE OF REFUSE, PHYSICAL CONTAMINANTS, AND MATERIAL TOXIC TO PLANT GROWTH; IT IS NOT ACCEPTABLE FOR THE MULCH MATERIAL TO CONTAIN GROUND CONSTRUCTION DEBRIS, BIOSOLIDS, OR MANURE.
4. SOCK MATERIAL WILL BE 100% BIODEGRADABLE, PHOTODEGRADABLE, OR RECYCLABLE SUCH AS BURLAP, TWINE, UV PHOTOBIODEGRADABLE PLASTIC, POLYESTER, OR ANY OTHER ACCEPTABLE MATERIAL.
5. MULCH SOCKS SHOULD BE USED AT THE BASE OF SLOPES NO STEEPER THAN 2:1 AND SHOULD NOT EXCEED THE MAXIMUM SPACING CRITERIA PROVIDED IN CITY OF AUSTIN ENVIRONMENTAL CRITERIA MANUAL TABLE 1.4.5.F.1 FOR A GIVEN SLOPE CATEGORY.
6. ACCUMULATED SILT SHALL BE REMOVED WHEN IT REACHES A DEPTH OF 150mm (6 inches). THE SILT SHALL BE DISPOSED OF ON AN APPROVED SITE AND IN SUCH A MANNER THAT WILL NOT CONTRIBUTE TO ADDITIONAL SILTATION.

<p>CITY OF AUSTIN WATERSHED PROTECTION DEPARTMENT</p>	<p>MULCH SOCK</p>
<p><i>Megan S. Ryan, P.E.</i> 08/24/2010 ADOPTED</p>	<p>THE ARCHITECT/ENGINEER ASSUMES RESPONSIBILITY FOR APPROPRIATE USE OF THIS STANDARD.</p> <p style="text-align: right;">STANDARD NO. 648S-1</p>

Materials:

TECHNICAL SPECIFICATION

1. Mulching material can be manufactured on or off the project site and may consist of shredded bark, stump grindings, or composted bark.
2. The mulch shall have the following composition:
 - a. Wood chips shall be produced from a 3-inch minus screen process (equivalent to TxDOT item 161, Compost, Section 1.6.2.B Wood Chip Requirements).
 - b. Large portions of silts, clays, or fine sands are not acceptable
 - c. The pH of the mulch shall be between 5.5 and 8.5.
 - d. The organic matter content shall be greater than or equal to 25% on a dry weight basis.
3. Mulch material must be free of refuse, physical contaminants, and material toxic to plant growth. It is not acceptable for the mulch material to contain ground construction debris, biosolids, manure, or recyclable material.
4. The sock material mesh opening shall be equal to or less than 3/8 inch (10 mm) and the material tensile strength shall be equal to or greater than 202 psi (14.2 kg/cm²).

Execution:

1. Use 12 or 18-inch diameter mulch socks for all sediment control applications. This diameter of mulch sock material has proven to be the most consistent for all sediment control applications. (TxDOT, April 2006)
2. Install as shown in above figure.
3. Mulch socks should be used at the base of slopes no steeper than 2:1
4. Place mulch socks at a 5' or greater distance away from the toe of the slopes to maximize space available for sediment deposition.
5. When placed on level contours, sheet flow of water should be perpendicular to the mulch sock at impact and unconcentrated.
6. Install mulch socks using rebar (#5 minimum with safety caps) a minimum of 48" in length placed on 2' centers. In order to prevent the movement or floating of the mulch sock during rain events or construction operations, install steel posts on alternating sides of the sock. Drive the posts into the ground a minimum depth of 24", leaving less than 12" of post above the exposed mulch sock.
7. In order to prevent water flowing around the ends of the mulch socks, point the ends of the socks up slope. To prevent water from flowing between the gaps at adjacent ends of mulch socks, overlap the ends of adjacent mulch socks a minimum of 12". Never stack mulch socks on top of each other.
8. Socks should be placed using "smiles" and "j-hooks".
9. For steeper slopes, an additional mulch sock can be constructed on the top of the slope and within the slope area as determined by specific field conditions. Multiple mulch socks are recommended on steeper slopes.
10. Do not use mulch socks in area of concentrated flow as they are intended to control sheet flow only.

**EXHIBIT G Stabilized Construction Exit –
Bull Rock and Cattle Guard Detail**

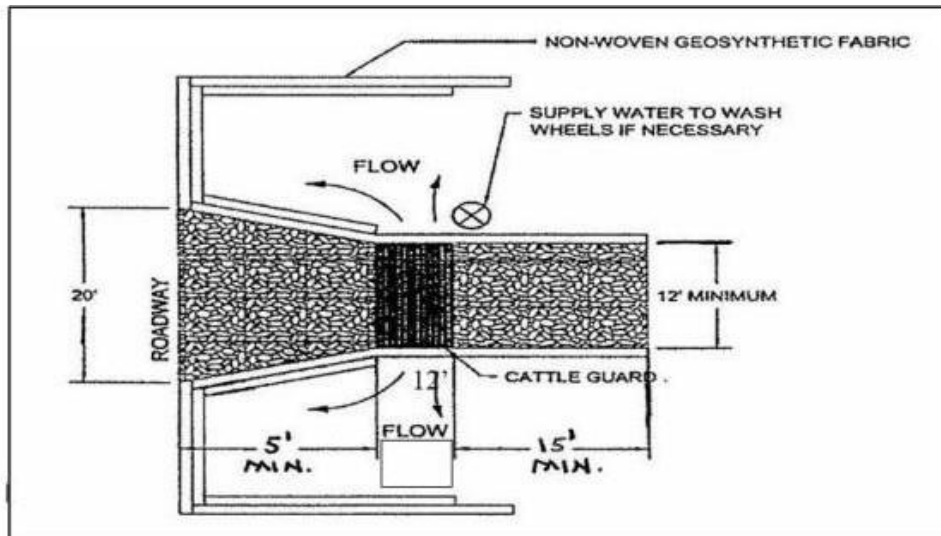

NOTES:

1. THE GRID CONSISTS OF PIPES OR TUBES WITH A MINIMUM DIAMETER OF 3 INCHES, SPACED SUCH THAT THERE IS A MINIMUM CLEAR DISTANCE OF 4 1/2 INCHES BETWEEN THEM. ELEVATE THE GRID ABOVE THE GROUND SURFACE A MINIMUM OF 8 INCHES TO ALLOW WATER, DEBRIS AND SOIL TO DRAIN.
2. THE GRID SHALL BE DESIGNED TO SUPPORT THE WEIGHT OF ANY AND ALL VEHICLES ENTERING AND LEAVING THE CONSTRUCTION SITE.
3. THE GRID SHALL BE FIRMLY PLACED IN THE GROUND AT THE EXIT, AND SHALL BE OF SUFFICIENT LENGTH THAT THE AGITATION WILL REMOVE THE SOIL FROM THE TIRES, OR A MINIMUM OF 12 FEET.
4. AT THE STREET SIDE APPROACH OF THE GRID, THERE SHALL BE AN IMPERVIOUS SURFACE OR IT SHALL CONSIST OF 3" X 5" ANGULAR CRUSHED STONE/ROCK 5 FEET IN LENGTH MINIMUM, AND 8 INCHES DEEP, MINIMUM. ON THE JOB SITE SIDE OF THE GRID, THERE SHALL BE 3" X 5" ANGULAR CRUSHED STONE/ROCK 15 FEET IN LENGTH, MINIMUM, 8 INCHES DEEP, MINIMUM. THE STEEL GRID WILL BE BETWEEN THE STREET SIDE APPROACH AND THE JOB SITE CRUSHED STONE/ROCK. ALL CRUSHED STONE/ROCK SHALL HAVE FILTER FABRIC PLACED BENEATH IT.
5. THE STEEL GRID AREA SHALL BE USED AS THE TIRE WASH AREA. WHEN TIRE WASH IS IN USE (RAINY OR MUDDY DAYS), THE AREA SHALL BE MANNED AND THE TIRES SHALL BE WASHED USING A HIGH PRESSURE HOSE/NOZZLE.
6. THE AREA BENEATH THE GRID SHALL BE SLOPED SUCH THAT DEBRIS, SOIL AND WATER SHALL BE DIVERTED BACK ON TO THE CONSTRUCTION SITE OR TO A SEDIMENT BASIN. NO WATER, SOIL OR DEBRIS SHALL LEAVE THE CONSTRUCTION SITE, AND THE RESULTING DISCHARGE SHALL BE DISPOSED OF PROPERLY.

TECHNICAL SPECIFICATION**Materials:**

1. It shall consist of pipes or tubes spaced such that there is a minimum clear distance between the pipes or tubes of 4½ inches.
2. Minimum diameter of pipe or tube shall be 3 inches.
3. It shall be of sufficient length so that the agitation will remove the soil from the tires, or a minimum of 12 feet.
4. Rock – Use 3" X 5" diameter angular crushed stone/rock.

Execution:

1. It shall be elevated above the ground surface a minimum of 8 inches to allow water, debris and soil to drain.
2. It shall be designed to support any and all vehicles entering and leaving the construction site.
3. It shall be firmly placed in the ground at the exit.
4. At the street side approach of the grid there shall be an impervious surface or it shall consist angular crushed stone/rock approximately 5 feet in length, minimum, and 8 inches deep, minimum. On the job site side of the grid, there shall angular crushed stone/rock 15 feet in length, a minimum of 8 inches deep. The steel grid will be between the street side approach and the job site crushed stone/rock. All crushed stone/rock shall have filter fabric beneath the stone/rock.
5. Steel grid area shall be used as the tire wash area. When tire wash is in use (rainy or muddy days), the area shall be manned and the tires shall be washed using a high pressure hose/nozzle.
6. The area beneath the grid shall be sloped such that debris, soil and water shall be diverted back onto the construction site or to a sediment basin. No water, soil, or debris shall leave the construction site. The resulting discharge shall be disposed of properly.
7. The stabilized construction exit shall be properly maintained throughout the entire construction process until removal is approved by UT Austin

TECHNICAL SPECIFICATION

**EXHIBIT H Stabilized Construction Exit
- Bull Rock Detail**

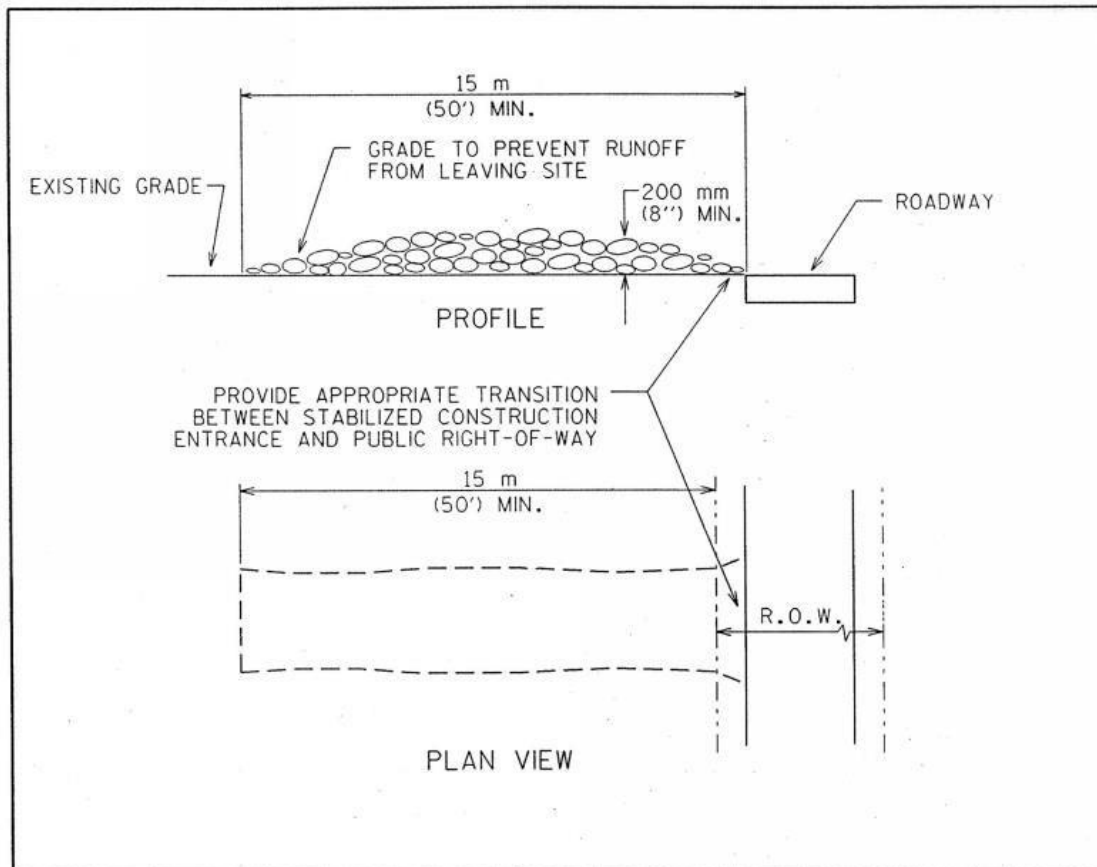

NOTES:

1. STONE SIZE: 75-125 mm (3-5") OPEN GRADED ROCK.
2. LENGTH: AS EFFECTIVE BUT NOT LESS THAN 15 m (50').
3. THICKNESS: NOT LESS THAN 200 mm (8").
4. WIDTH: NOT LESS THAN FULL WIDTH OF ALL POINTS OF INGRESS/EGRESS.
5. WASHING: WHEN NECESSARY, VEHICLE WHEELS SHALL BE CLEANED TO REMOVE SEDIMENT PRIOR TO ENTRANCE ONTO PUBLIC ROADWAY. WHEN WASHING IS REQUIRED, IT SHALL BE DONE ON AN AREA STABILIZED WITH CRUSHED STONE AND DRAINS INTO AN APPROVED TRAP OR SEDIMENT BASIN. ALL SEDIMENT SHALL BE PREVENTED FROM ENTERING ANY STORM DRAIN, DITCH OR WATERCOURSE USING APPROVED METHODS.
6. MAINTENANCE: THE ENTRANCE SHALL BE MAINTAINED IN A CONDITION THAT WILL PREVENT TRACKING OR FLOWING OF SEDIMENT ONTO PUBLIC ROADWAY. THIS MAY REQUIRE PERIODIC TOP DRESSING WITH ADDITIONAL STONE AS CONDITIONS DEMAND, AS WELL AS REPAIR AND CLEAN OUT OF ANY MEASURE DEVICES USED TO TRAP SEDIMENT. ALL SEDIMENTS THAT IS SPILLED, DROPPED, WASHED OR TRACKED ONTO PUBLIC ROADWAY MUST BE REMOVED IMMEDIATELY.
7. DRAINAGE: ENTRANCE MUST BE PROPERLY GRADED OR INCORPORATE A DRAINAGE SWALE TO PREVENT RUNOFF FROM LEAVING THE CONSTRUCTION SITE.

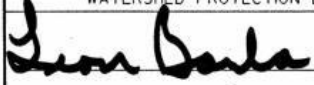
CITY OF AUSTIN WATERSHED PROTECTION DEPARTMENT	STABILIZED CONSTRUCTION ENTRANCE	
 ADOPTED	THE ARCHITECT/ENGINEER ASSUMES RESPONSIBILITY FOR APPROPRIATE USE OF THIS STANDARD.	STANDARD NO. 641S-1

Materials:

TECHNICAL SPECIFICATION

1. Stone/Rock – use 3" X 5" clean open graded stone/rock

Execution:

1. All trees, brush, stumps, obstructions and other objectionable material shall be removed and disposed of in a manner that will not interfere with the excavation and construction of the entrance. The entrance shall not drain onto the public right of way or shall not allow surface water runoff to exit the construction site.
2. When necessary, vehicle wheels shall be cleaned to removed sediment prior to entrance onto public right of way. When vehicle washing is required, it shall be done on an area stabilized with crushed stone, which drains into an approved sediment trap or sediment basin. All sediment shall be prevented from entering any storm drain, ditch, or watercourse through use of gravel bags, silt fence, or other methods approved by the Engineer or designated representative.
3. The entrance shall be maintained in a condition that will prevent tracking or disposition of sediment onto public right of way. This restriction may require periodic top dressing with additional stone as conditions demand, as well as the repair and/or cleanout of any measures used to trap sediment. All sediment that is dripped, spilled, washed, or tracked onto public right of way must be removed immediately.

EXHIBIT I Stabilized Construction Exit – Tracking Control Mat Detail



GENERAL INFORMATION

The FODS Composite trackout control system is designed to be used as a temporary construction entrance which provides site access while minimizing sediment leaving the site. The top surface of the FODS mat is a geometric pattern formed in the shape of pyramids. The mats are unidirectional and are meant to have the staggered pyramids in the direction of travel. Individual mats are connected together with hardware to form various configurations to fit your jobsite.

- Mat Size: 12'(w) x 7' (l) x 3 3/4" (t) (2 7/8" pyramid height)
- Mat Weight: 430lbs
- Pallet Size: 8-Mats
- Truck-Load: 96-Mats
- Hardware boxes are contained within the palletized mats



FEATURES & BENEFITS

- Re-Usable
- Increased Effectiveness at Reducing Site Trackout
- U/V Stable
- Highly Visible
- Easy to Clean
- Economical
- Recyclable / Reduces Waste
- Extreme Durability
- Rapid Installation & Removal
- Excavation not required
- Chemical Resistant
- Rock-less
- Reduces Waste
- Easy and efficient to transport from site-site

TYPICAL INSTALLATION LAYOUTS

Each site must be evaluated to determine the proper layout, width, and duration of the FODS Trackout Control System (FTCS) based site conditions, entry and exit egress, traffic levels, site soil conditions, and ability to the maintain trackout system. Outlined below are a number of common layouts, the mats are unidirectional and due to the versatility of the mats design the FTCS can be engineered to fit the needs of any site:



FODS 1x4

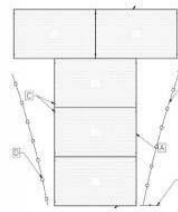

FODS 1x4T

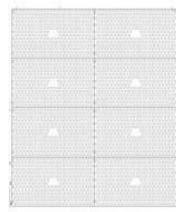

FODS 2x4

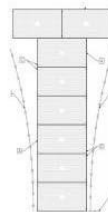

FODS 1x7T



FODS 2x7

FODS LLC | The Mud Stops Here | GetFods.com | 1-844-200-3637



COMMON USERS

- Heavy Civil Construction
- Urban Construction / Urban In-Fill
- Bridge & Highway Projects
- Residential Construction
- Land Development
- Forestry
- Energy Exploration
- Oil & Gas Pipeline
- Electrical Power-line
- Temporary Event Access
- Landfill & Waste Management
- Mining



SUITABLE INSTALLATION SUBSTRATE

- Un-Excavated Soil
- Excavated Soil (Min CBR: 4)
- Asphalt
- Concrete

FODS Trackout Control System should be installed near the site exit point, as close to the location where vehicles enter the roadway as is safely as possible. FODS mats should not be installed at a low point on the site where water will pool.



FODS ANCHORING SYSTEMS

- Form-Stakes (18" or 24")
- Cable Earth Anchor
- All-Thread Earth Anchor
- Concrete Sleeve Anchor (asphalt)

CLEANING / MAINTENANCE

- Mats should be cleaned once 2.5" of sediment has built up in the lane of travel.
- Skid-steer broom attachment
 - FODS Shovel
 - Street Sweeper (requires adjusted bristle head)
 - Pressure Washer (must have ability to contain water)
 - Water Truck (must have ability to contain water)

WARNINGS

- Caution is to be used when crossing mats with metal tracked equipment.
- Equipment with aggressive metal tracks should not cross mats
- Do not drag metal equipment across mats
- Do not use mats for bridging

*****Before using earth anchors, call 811 for locates to mark underground utilities*****



FODS LLC | The Mud Stops Here | GetFods.com | 1-844-200-3637

TECHNICAL SPECIFICATION

EXHIBIT J

Concrete, Paint and Stucco Washout Detail

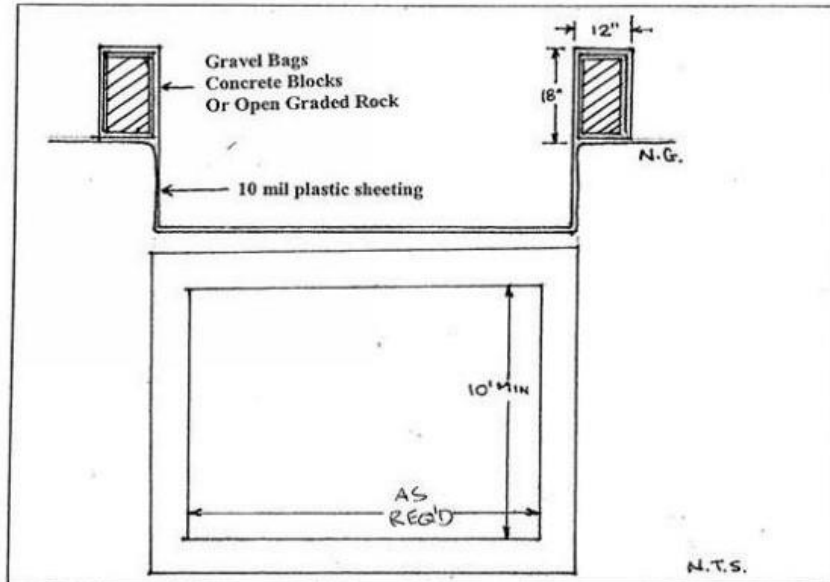

NOTES:

1. THE EXCAVATION FOR THE CONCRETE TRUCK WASHOUT SHALL BE A MINIMUM OF 10 FEET WIDE AND OF SUFFICIENT LENGTH AND DEPTH TO ACCOMMODATE 7 GALLONS OF WASHOUT WATER AND CONCRETE PER TRUCK PER DAY AND/OR 50 GALLONS OF WASHOUT WATER AND CONCRETE PER PUMP TRUCK PER DAY.

2. IN THE EVENT THAT THE CONCRETE TRUCK WASHOUT IS CONSTRUCTED ABOVE GROUND, IT SHALL BE 10 FEET WIDE AND 10 FEET LONG, WITH THE SAME REQUIREMENTS FOR CONTAINMENT AS DESCRIBED IN ITEM 1.

3. THE CONTAINMENT AREA SHALL BE LINED WITH 10 MIL PLASTIC SHEETING WITHOUT HOLES OR TEARS. WHERE THERE ARE SEAMS, THESE SHALL BE SECURED ACCORDING TO MANUFACTURERS' DIRECTIONS.

4. THE BERM CONSISTING OF GRAVEL BAGS, CONCRETE BLOCKS OR OPEN GRADED ROCK SHALL BE NO LESS THAN 18 INCHES HIGH AND NO LESS THAN 12 INCHES WIDE.

5. THE PLASTIC SHEETING SHALL BE OF SUFFICIENT SIZE SO THAT IT WILL OVERLAP THE TOP OF THE CONTAINMENT AREA AND BE WRAPPED AROUND THE GRAVEL BAGS, CONCRETE BLOCKS OR OPEN GRADED ROCK AT LEAST 2 TIMES.

6. THE GRAVEL BAGS OR CONCRETE BLOCKS SHALL BE PLACED ABUTTING EACH OTHER TO FORM A CONTINUOUS BERM AROUND THE OUTER PERIMETER OF THE CONTAINMENT AREA.

7. THE WASHOUT MATERIAL IN THE CONTAINMENT AREA SHALL NOT EXCEED 50% OF CAPACITY AT ANY ONE TIME.

8. SOLIDS SHALL BE REMOVED FROM CONTAINMENT AREA AND DISPOSED OF PROPERLY. ANY DAMAGE TO THE PLASTIC SHEETING SHALL BE REPAIRED OR SHEETING REPLACED BEFORE THE NEXT.

TECHNICAL SPECIFICATION**Materials:**

1. Gravel bags, concrete blocks or open graded rock
2. 10 mil plastic sheeting without any holes or tears. Seams shall be sealed according to manufacturer's recommendations.

Execution:

1. Concrete Truck Washout (self-installed) shall be constructed so that it will be able to accommodate the maximum number of anticipated concrete trucks that will be cleaned on any given day at any given time using 7 gallons of water for washout per truck or 50 gallons of water to wash out pump trucks. The area utilized to contain the wash water and concrete solids cleaned from the trucks will be a minimum of 10 feet in width. The containment area will be covered with 10 mil plastic sheeting. The gravel bags, concrete blocks or open graded rocks shall line the outside perimeter and shall be double wrapped with the 10 mil plastic sheeting to prevent any potential for runoff from the containment area.
2. The concrete truck washout containment area shall be maintained in a condition that will not allow concrete buildup within the containment area to exceed 50% of the storage capacity.
3. The concrete truck washout area will be removed when it is no longer necessary to wash out concrete trucks on the site.
4. Equipment Cleaning: Clean equipment in a manner that does not create any discharge of cleaning agents, paints, oil or solvents to a storm sewer, waterway or onto the ground. Soaps and detergents must never be discharged to the ground. Cement handling equipment must be rinsed in a contained area and there must be no drainage off-site or onto to ground.
5. When rinsing painting equipment/tools outside, rinse water must be contained in a bucket or other container for appropriate disposal. Water based or latex paint rinse water may be discharged to the sanitary sewer only with permission/approval from EHS.
6. Oil based paint wastes, including solvents and thinners, must not be disposed of in the sanitary sewer; they must be collected and disposed of through the contractor's disposal company in accordance with applicable laws and regulations.
7. Discharges from pressure washing using soaps or chemicals must not be allowed to enter a storm sewer. The wastewater will need to be collected with a berm and vacuumed (transported to appropriate disposal site). If the rinse only contains water and dirt (sediment) it may be spread on a grass area or contained/filtered with clean water allowed to enter storm sewer. In some cases, it may also be possible to discharge to a sanitary sewer with permission from EHS.

TECHNICAL SPECIFICATION

EXHIBIT K Diversion Dike Detail

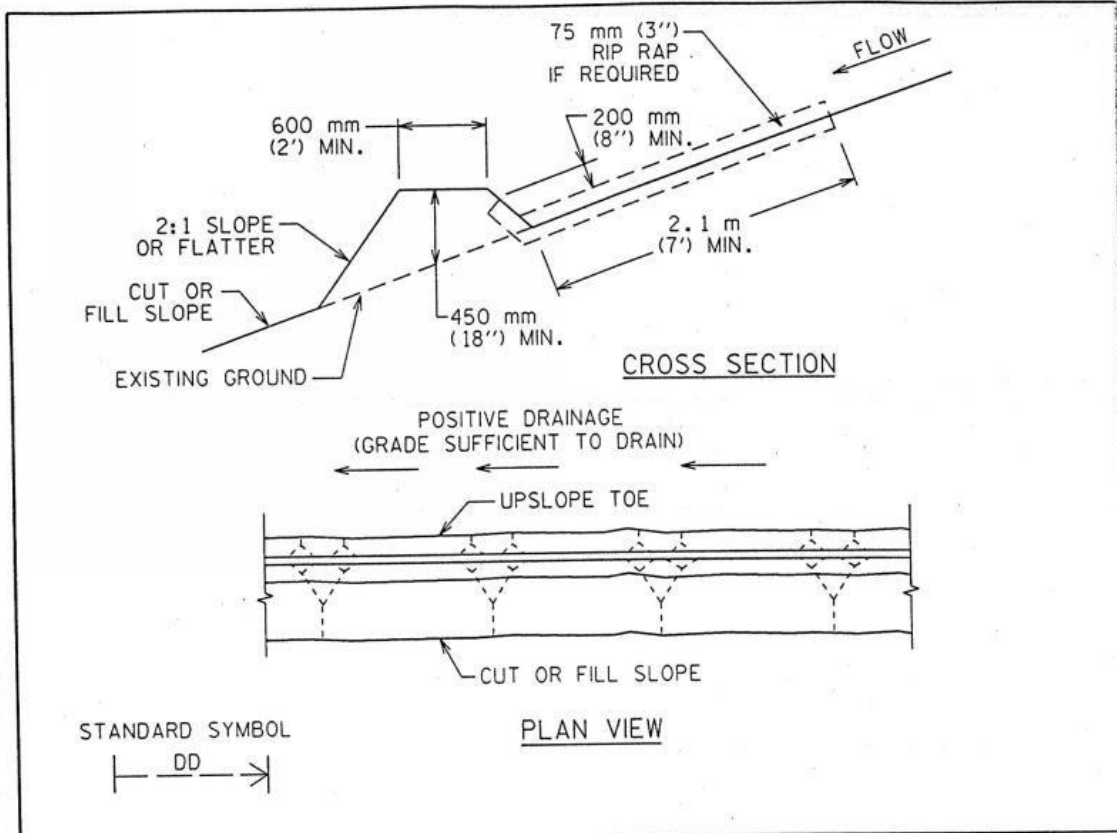

GENERAL NOTES :

1. ALL DIKES SHALL BE MACHINE COMPACTED.
2. ALL DIVERSION DIKES SHALL HAVE POSITIVE DRAINAGE TO AN OUTLET.
3. a. DIVERTED RUNOFF FROM A PROTECTED OR STABILIZED AREA SHALL HAVE ITS OUTLET FLOW DIRECTED TO AN UNDISTURBED STABILIZED AREA OR INTO A LEVEL SPREADER OR GRADE STABILIZATION STRUCTURE.
- b. DIVERTED RUNOFF FROM A DISTURBED OR EXPOSED AREA SHALL BE CONVEYED TO A SEDIMENT TRAPPING DEVICE, SUCH AS A ROCK BERM, BRUSH BERM, STONE OUTLET STRUCTURE, SEDIMENT TRAP OR SEDIMENT BASIN OR TO AN AREA PROTECTED BY ANY OF THESE PRACTICES.
4. UNLESS OTHERWISE SPECIFIED, EROSION STABILIZATION SHALL BE OPEN GRADED ROCK 75 TO 125 mm (3 TO 5 inches) IN DIAMETER EMBEDDED IN SOIL SURFACE.
5. INSPECTION SHALL BE CONDUCTED WEEKLY OR AFTER EACH RAINFALL EVENT.

<p>CITY OF AUSTIN WATERSHED PROTECTION DEPARTMENT</p>	<p>DIVERSION DIKE</p>	
<p><i>[Signature]</i> 3.27.00 ADOPTED</p>	<p>THE ARCHITECT/ENGINEER ASSUMES RESPONSIBILITY FOR APPROPRIATE USE OF THIS STANDARD.</p>	<p>STANDARD NO. 622S-1</p>

- :
1. Stone stabilization (required for velocities in excess of 6 fps) should consist of riprap placed in a layer at least 3 inches thick and should extend a minimum height of 3 inches above the design water surface up the existing slope and the upstream face of the dike. Stabilization riprap should conform to the following specifications.

<i>Channel Grade</i>	<i>Riprap Stabilization</i>
0.5-1%	4 inch rock
1. 1-2%	6 inch rock
2. 1-4%	8 inch rock
4.1-5%	8-12 inch riprap

2. Geotextile fabric should be a non-woven polypropylene fabric designed specifically for use as a soil filtration media with an approximate weight of 6oz/yd², a Mullen burst rating of 140 psi, and having an equivalent opening size (EOS) greater than #50 sieve.

Execution:

1. Diversion dikes shall be formed and shaped using compacted fill, and shall not intercept runoff from more than 10 acres. The dike shall have a minimum top width of 2 feet, and a minimum height of 18 inches. Soil shall have side slopes of 2.1 or flatter, and shall be placed in 8-inch lifts. Compact soil to 95% standard proctor density. Where protected slopes exceed 2 percent, the uphill side of diversion dike shall be stabilized with crushed stone or erosion control matting to a distance of not less than 7 feet from toe of dike. The channel that is formed by the diversion dike must have positive drainage for its entire length to a stabilized outlet, such as a rock berm, sandbag berm, or stone outlet structure. Storm water shall not be allowed to overflow the top of diversion dike at any point other than the stabilized outlet.
2. Maintain the diversion dike in a condition that allows the storm water runoff to be diverted away from exposed slopes. Repair any failures at top of dike and remove sediment as necessary behind the dike to allow positive drainage to a stabilized outlet.
3. Remove diversion dike when the exposed slopes being protected are stabilized with vegetation or other permanent cover

Materials

EXHIBIT L Interceptor Swale Detail

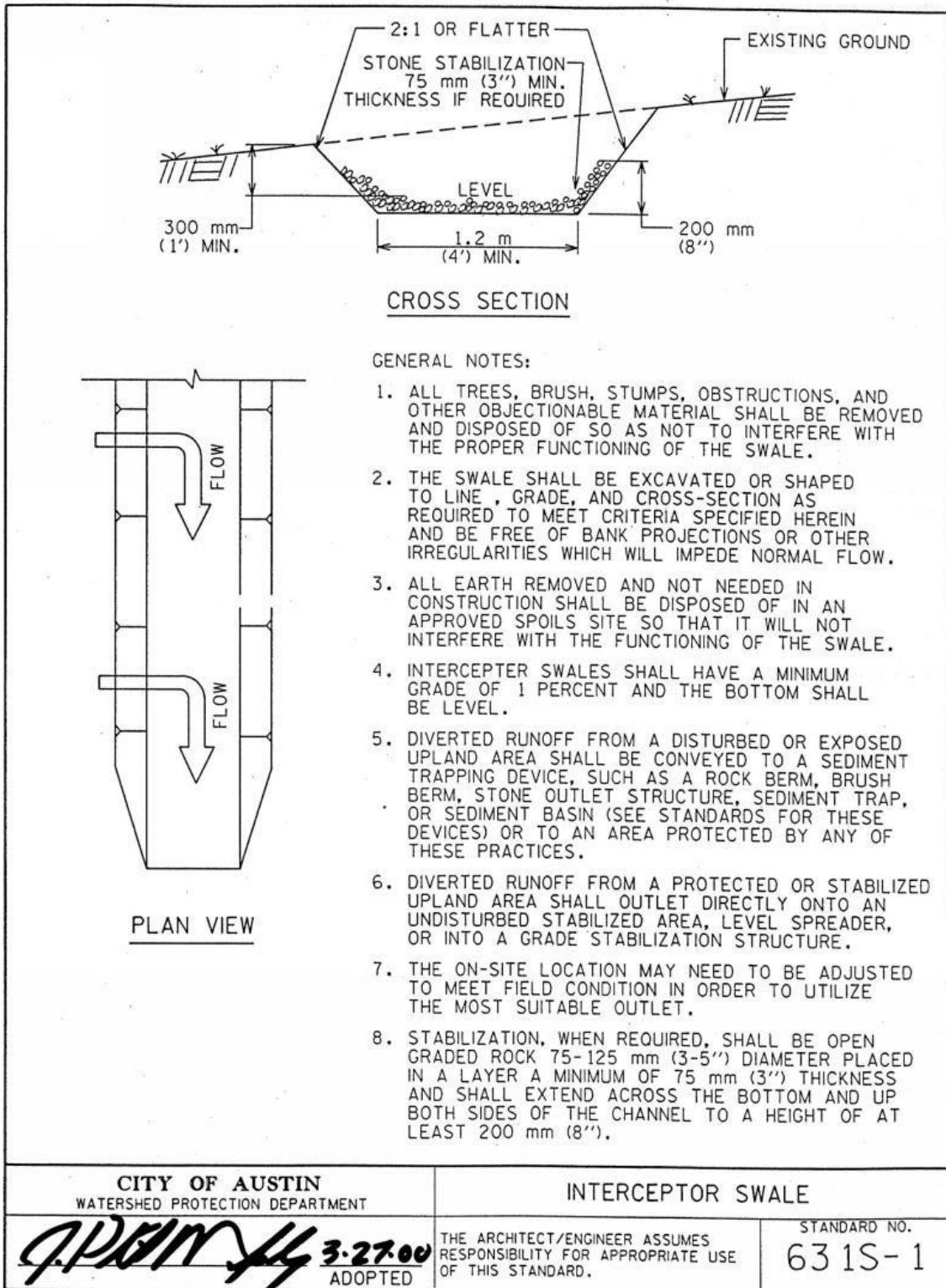

TECHNICAL SPECIFICATION

The University of Texas at Austin

1. Stone stabilization should be used when grades exceed 2% or velocities exceed 6 feet per second and should consist of a layer of crushed stone 3" thick, riprap or high velocity erosion control mats.
2. Stabilization should extend across the bottom of the swale and up both sides of the channel to a minimum height of 3" above the design water surface election based on a 2-year, 24-hour storm.

Execution:

1. An interceptor swale shall be implemented to prevent on or off- site storm water from entering a disturbed area, or prevent sediment-laden runoff from leaving the site or disturbed area. The interceptor swale shall be excavated as required by the SWPPP drawings, with side slopes of 2:1 or flatter. This shall include all labor and equipment associated with the installation and maintenance of the swale as shown on the construction documents. Constructed swale may be vshaped or trapezoidal with a flat bottom, depending on the volume of water being channeled. Sediment laden runoff from swale shall be directed to a stabilized outlet or sediment- trapping device. Flow line of swale shall have a continuous fall for its entire length and shall not be allowed to overflow at any other points along its length.
2. Maintain interceptor swale in a condition that allows the storm water runoff to be channeled away from disturbed areas. Remove sediment in swale as necessary to maintain positive drainage to a stabilized outlet
3. Fill in or remove swale after the disturbed area/s being protected is completely stabilized as specified.

Materials

EXHIBIT M Organic Mulches Detail

MULCHING MATERIAL

USE UNTREATED WOOD CHIPS PRODUCED FROM A 3 (THREE) INCH MINUS SCREENING PROCESS (EQUIVALENT TO TXDOT ITEM 161, COMPOST, SECTION 1.6.2.B, WOOD CHIP REQUIREMENTS).

MULCH CONSISTS PRIMARILY OF ORGANIC MATERIAL, SEPARATED AT THE POINT OF GENERATION, AND MAY INCLUDE: SHREDDED BARK, STUMP GRINDINGS, OR COMPOSTED BARK.

LARGE PORTIONS OF SILT, CLAYS, OR FINE SANDS ARE NOT ACCEPTABLE IN THE MULCH.

NOTES:

- MULCHING IS PERFORMED AFTER GRADING AND SOIL SURFACE PREPARATION IS COMPLETED. THE EFFECTIVENESS OF THE MULCHING MATERIAL DEPENDS ON GOOD CONTACT BETWEEN THE SOIL AND MULCHING MATERIAL. PROVIDE A SMOOTH MULCHING APPLICATION SURFACE BY TRACKING, ROLLING, RAKING, ETC. TO ENSURE OPTIMAL MULCH TO SOIL CONTACT.
- APPLY MULCHING MATERIAL A MINIMUM OF THREE (3) FEET OVER THE SHOULDER AND BEYOND THE BASE OF THE SLOPE OR INTO EXISTING VEGETATION WHERE POSSIBLE TO PREVENT RILL FORMATION AND TRANSPORT OF THE MATERIAL. THE MULCHING MATERIAL SHALL BE PLACED EVENLY AND UNIFORMLY TO PROVIDE 100% COVERAGE.
- MULCH MATERIAL MUST BE FREE OF REFUSE, PHYSICAL CONTAMINANTS, AND MATERIAL TOXIC TO PLANT GROWTH; IT IS NOT ACCEPTABLE FOR THE MULCH MATERIAL TO CONTAIN GROUND CONSTRUCTION DEBRIS, BIOSOLIDS, OR MANURE.
- THE MULCHED AREA SHALL BE INSPECTED REGULARLY AND AFTER EACH LARGE RAINFALL. ANY REQUIRED REPAIRS SHALL BE MADE IMMEDIATELY, WITH ADDITIONAL MULCHING MATERIAL PLACED ON TOP OF THE MULCH TO REACH THE RECOMMENDED THICKNESS.
- WHEN THE MULCH IS DECOMPOSED, CLOGGED WITH SEDIMENT, ERODED OR INEFFECTIVE, IT MUST BE REPLACED OR REPAIRED.

Image adopted from City of Austin Standards Manual, Notes tailored to the University of Texas at Austin

: Mulch shall be one or more of the following:

TECHNICAL SPECIFICATION

The University of Texas at Austin

1. Straw – from broken straw bales that are free of weed and grass seed where the grass from the seed is not desired vegetation for the area to be protected
2. Wood Chips – from chipped limbs of cleared trees on site, or delivered in chipped form, in bulk quantities of pine, cedar or cypress. Wood chips of all species shall be partially decomposed to alleviate nitrogen depletion of the soil in areas where existing vegetation is to be preserved and protected. In addition, wood chips are not to be used on slope greater than 4 percent.
3. Shredded Mulches – from cedar, mechanically shredded, and capable of forming an interlocking mat following placement, and after sufficient wetting and drying has taken place naturally.

Execution:

1. Apply mulching a minimum of three feet over the shoulder and beyond the base of the slope or into existing vegetation where possible to prevent rill formation and transport of the material. The mulching material shall be placed evenly and uniformly to provide 100% cover.
2. When the mulch is decomposed, clogged with sediment, eroded or ineffective, it must be replaced or repaired.